

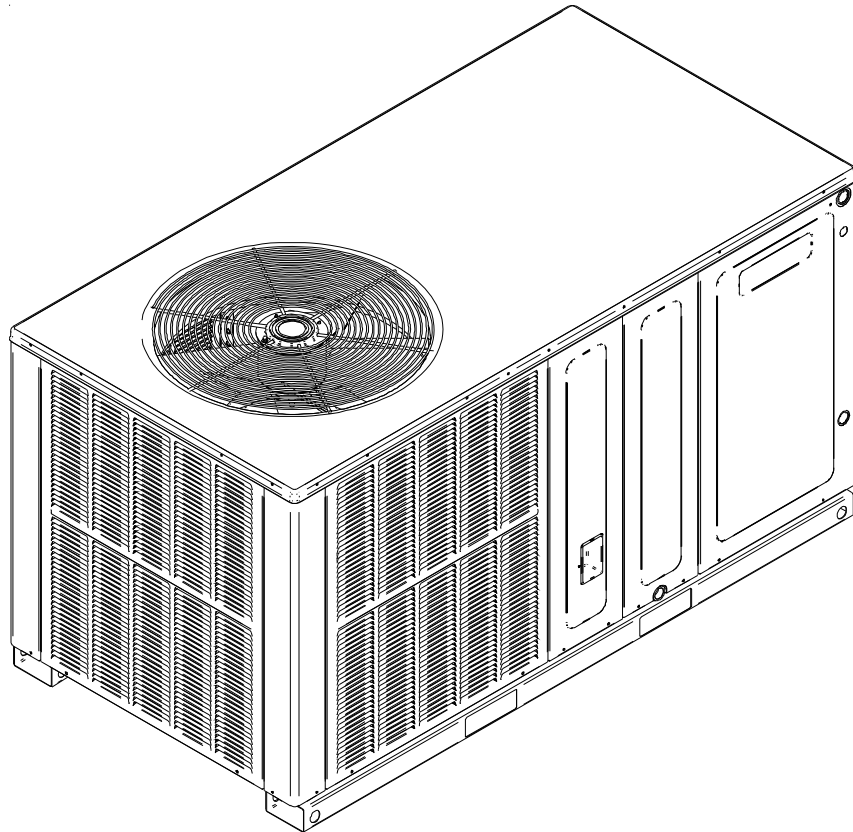

TECHNICAL MANUAL

GPH 13 H SERIES HORIZONTAL Package Heat Pump Units with R-410A

- Refer to Service Manual RS6300011 (Horizontal) for installation, operation, and troubleshooting information.
- All safety information must be followed as provided in the Service Manual.
- Refer to the appropriate Parts Catalog for part number information.
- Models listed on page 3



This manual is to be used by qualified, professionally trained HVAC technicians only. Goodman does not assume any responsibility for property damage or personal injury due to improper service procedures or services performed by an unqualified person.

RT6332011r3
November 2010

PRODUCT IDENTIFICATION

The model and manufacturing number are used for positive identification of component parts used in manufacturing. Please use these numbers when requesting service or parts information.

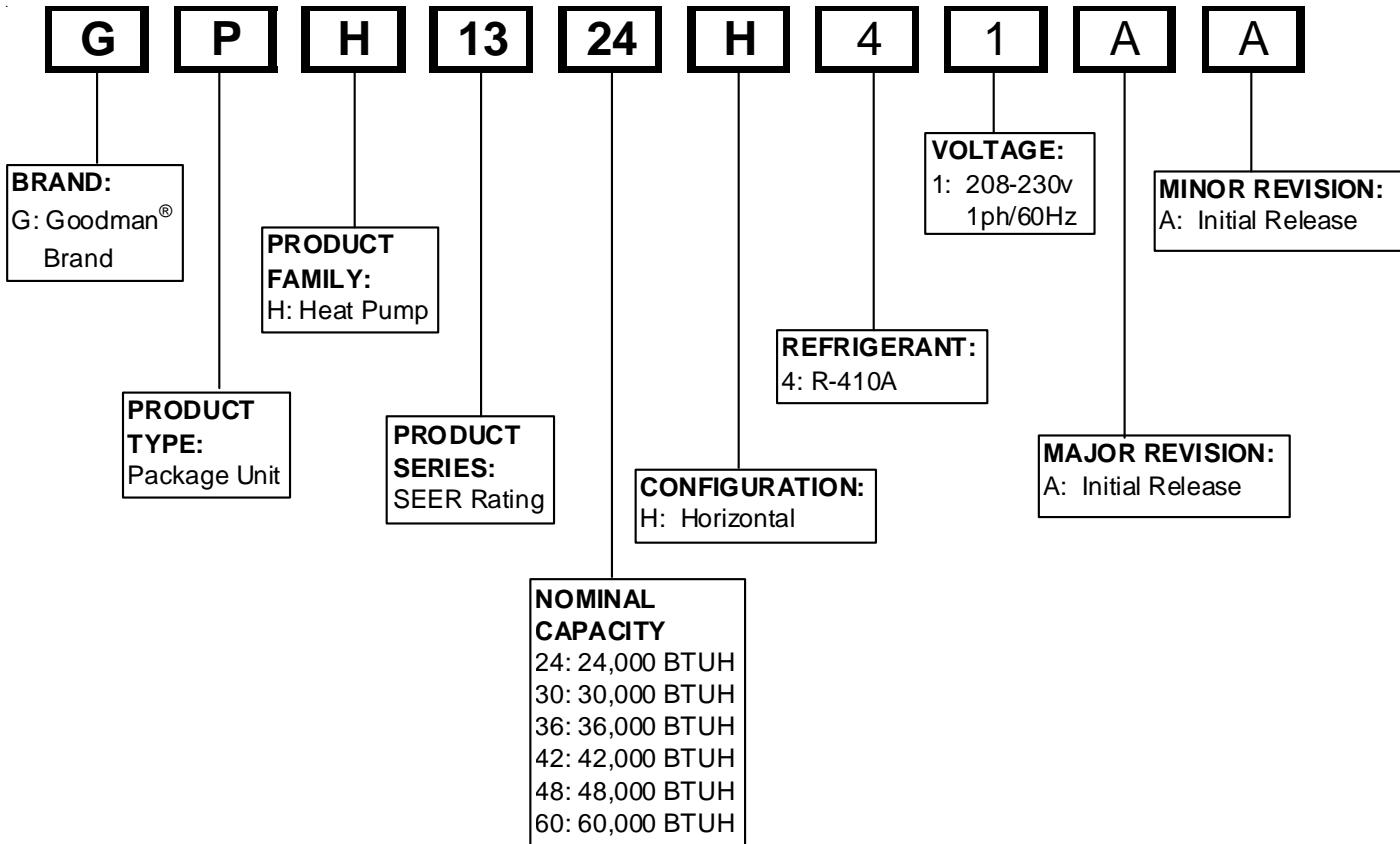

WARNING

HIGH VOLTAGE!

Disconnect ALL power before servicing or installing this unit. Multiple power sources may be present. Failure to do so may cause property damage, personal injury or death.

WARNING

Goodman will not be responsible for any injury or property damage arising from improper service or service procedures. If you install or perform service on this unit, you assume responsibility for any personal injury or property damage which may result. Many jurisdictions require a license to install or service heating and air conditioning equipment.

WARNING

Installation and repair of this unit should be performed ONLY by individuals meeting (at a minimum) the requirements of an "entry level technician" as specified by the Air-Conditioning, Heating, and Refrigeration Institute (AHRI). Attempting to install or repair this unit without such background may result in product damage, personal injury or death.

PRODUCT IDENTIFICATION

The model and manufacturing number are used for positive identification of component parts used in manufacturing. Please use these numbers when requesting service or parts information.

GPH1324H41AB

GPH1330H41AB

GPH1336H41AC

GPH1342H41AB

GPH1348H41BB

GPH1360H41BB



The United States Environmental Protection Agency ("EPA") has issued various regulations regarding the introduction and disposal of refrigerants introduced into this unit. Failure to follow these regulations may harm the environment and can lead to the imposition of substantial fines. These regulations may vary by jurisdiction. Should questions arise, contact your local EPA office.



Do not connect or use any device that is not design certified by Goodman for use with this unit. Serious property damage, personal injury, reduced unit performance and/or hazardous conditions may result from the use of such non-approved devices.



To prevent the risk of property damage, personal injury, or death, do not store combustible materials or use gasoline or other flammable liquids or vapors in the vicinity of this appliance.

PRODUCT DESIGN

GPH Package Units are designed for outdoor installations only in either residential or light commercial applications.

The connecting ductwork (Supply and Return) can only be connected for horizontal airflow.

A return air filter must be installed behind the return air grille(s) or provision must be made for a filter in an accessible location within the return air duct. The minimum filter area should not be less than those sizes listed in the Specification Section. Under no circumstances should the unit be operated without return air filters.

A 3/4" pipe is provided for removal of condensate water from the indoor coil. In order to provide proper condensate flow, a drain trap is supplied and shipped loose inside the unit for field installation. (Do not reduce the drain line size).

Refrigerant flow control is achieved by use of restrictor orifices.

Package Heat Pump models use a combination of restrictor orifices and thermostatic expansion valves for refrigerant flow control.

Some heat pump models also have a suction line accumulator installed between the reversing valve and the compressor. The object of the accumulator is to:

1. Provide a liquid refrigerant storage vessel during prolonged system off cycles.
2. Store excess liquid refrigerant not needed by the system while running.
3. Return oil and saturated vapor to the compressor at a controlled rate.
4. Retain stored excess refrigerant during a sudden system pressure fluctuation such as seen in defrost cycles.

Refrigerant flow control is achieved by use of restrictor orifices. GPH units use the FasTest Access Fitting System, with a saddle that is either soldered to the suction and liquid lines or is fastened with a locking nut to the access fitting box (core) and then screwed into the saddle. **NOTE: The core must not be removed from the saddle until the refrigerant charge has been removed. Failure to do so could result in property damage or personal injury.**

The single phase units use permanent split capacitor (PSC) design compressors. Starting components are not required for these units. A low microfarad run capacitor assists the compressor to start and remains in the circuit during operation.

The outdoor fan and indoor blower motors are single phase capacitor type motors. GPH1360H41* units have EEM indoor blower motors that are energized by a 24V signal from the IBR and are constant torque motors with very low power consumption. The EEM features an integral control module.

Air for condensing (cooling cycle) or evaporation (heating cycle) is drawn through the outdoor coil by a propeller fan, and is discharged vertically out the top of the unit. The outdoor coil is designed for .0 static. No additional restriction (ductwork) shall be applied.

Conditioned air is drawn through the filter(s), field installed, across the coil and back into the conditioned space by the indoor blower.

Package Heat Pump indoor sections are designed to accept optional components such as auxiliary electric heaters and circuit breakers. Provisions for these components have been made at time of manufacture.

Location and Clearances

NOTE: To ensure proper condensate drainage, unit must be installed in a level position.

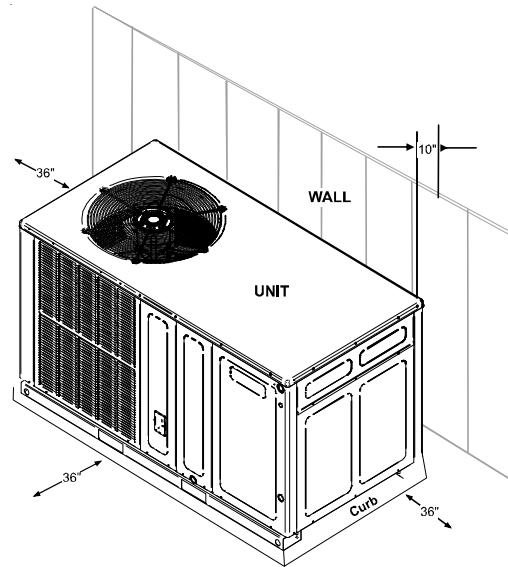

Outside Slab Installation - Horizontal (H)

NOTE: Roof overhang should be no more than 36" and provisions made to deflect the warm discharge air out from the overhang.

Minimum clearances are required to avoid air recirculation and keep the unit operating at peak efficiency.

PRODUCT DESIGN

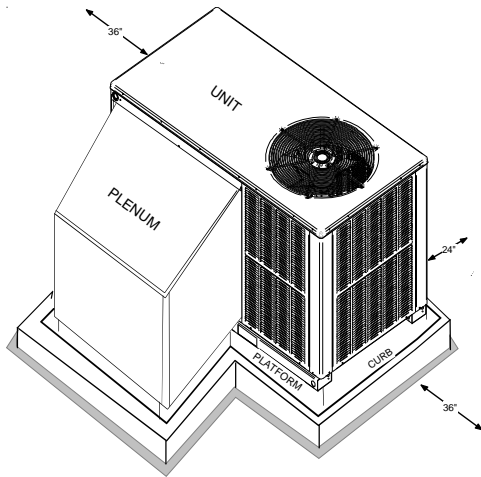

Rooftop Installation - Horizontal (H)

NOTE: To ensure proper condensate drainage, unit must be installed in a level position.

In installations where the unit is installed above ground level and not serviceable from the ground (Example: roof top installations) the installer must provide service platform for service person with rails or guards in accordance with local codes or ordinances, or, in their absence, with the latest edition of the Uniform Mechanical Code Section 305.

 WARNING
TO PREVENT POSSIBLE PROPERTY DAMAGE, THE UNIT SHOULD REMAIN IN AN UPRIGHT POSITION DURING ALL RIGGING AND MOVING OPERATIONS. TO FACILITATE LIFTING AND MOVING IF A CRANE IS USED, PLACE THE UNIT IN AN ADEQUATE CABLE SLING.

Refer to Roof curb Installation Instructions for proper curb installation. Curbing must be installed in compliance with the National Roofing Contractors Association Manual.

PRODUCT DESIGN

GPH1324-1360H41**

ELECTRICAL DATA (*Blower Only, Heat Mode)

Model and Heat Kit Usage	Circuit #1		Circuit #2		Actual kW & BTU at 240V
	Minimum Circuit Ampacity at 208 / 240V	Maximum Overcurrent Protection (amps) at 208 / 240V	Minimum Circuit Ampacity at 208 / 240V	Maximum Overcurrent Protection (amps) at 208 / 240V	
GPH1324H41**					
HKR05*,C*	24 / 27	30 / 30	----	----	4.75 / 16,200
HKR08*,C*	33 / 28	40 / 40	----	----	7.00 / 23,800
HKR10*,C*	45 / 51	60 / 60	----	----	9.50 / 32,400
GPH1330H41**					
HKR05*,C*	24 / 27	30 / 30	----	----	4.75 / 16,200
HKR08*,C*	34 / 39	40 / 40	----	----	7.00 / 23,800
HKR10*,C*	45 / 52	60 / 60	----	----	9.50 / 32,400
HKR15*,C*	45 / 52	60 / 60	22 / 25	30 / 30	14.25 / 48,600
GPH1336H41**					
HKR05*,C*	24 / 27	30 / 30	----	----	4.75 / 16,200
HKR08*,C*	34 / 39	40 / 40	----	----	7.00 / 23,800
HKR10*,C*	45 / 52	60 / 60	----	----	9.50 / 32,400
HKR15*,C*	45 / 52	60 / 60	22 / 25	30 / 30	14.25 / 48,600
GPH1342H41**					
HKR05*,C*	25 / 27	30 / 30	----	----	4.75 / 16,200
HKR08*,C*	34 / 39	40 / 40	----	----	7.00 / 23,800
HKR10*,C*	46 / 52	60 / 60	----	----	9.50 / 32,400
HKR15*,C*	46 / 52	60 / 60	22 / 25	30 / 30	14.25 / 48,600
HKR20*,C*	46 / 52	60 / 60	43 / 49	60 / 60	19.50 / 66,500
GPH1348H41**					
HKR05*,C*	25 / 28	30 / 30	----	----	4.75 / 16,200
HKR08*,C*	34 / 40	40 / 40	----	----	7.00 / 23,800
HKR10*,C*	46 / 53	60 / 60	----	----	9.50 / 32,400
HKR15*,C*	46 / 52	60 / 60	22 / 25	30 / 30	14.25 / 48,600
HKR20*,C*	46 / 52	60 / 60	43 / 49	60 / 60	19.50 / 66,500
GPH1360H41**					
HKR05*,C*	26 / 30	30 / 30	----	----	4.75 / 16,200
HKR08*,C*	36 / 40	40 / 40	----	----	7.00 / 23,800
HKR10*,C*	48 / 54	60 / 60	----	----	9.50 / 32,400
HKR15*,C*	48 / 54	60 / 60	22 / 25	30 / 30	14.25 / 48,600
HKR20*,C*	48 / 54	60 / 60	43 / 49	60 / 60	19.50 / 66,500

IMPORTANT NOTE: A separate power supply is required for the HKR heater kit.



WARNING

All wires and overcurrent protection devices are sized for use with electric heaters only and without refrigeration. If heaters are not installed with above wire size, overheating and fire could occur. See PACKAGE COOLING SPECIFICATIONS section for minimum circuit ampacity and maximum overcurrent protection during refrigeration cycle.

PRODUCT DIMENSIONS

GPH13[24-60]H41**

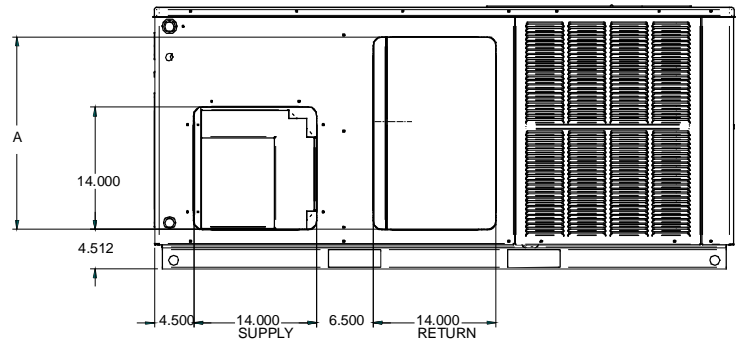
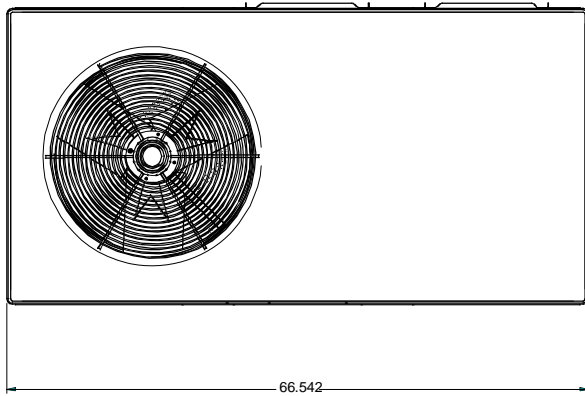

BACK VIEW
(DUCT OPENINGS)

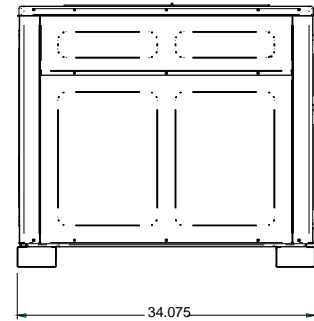
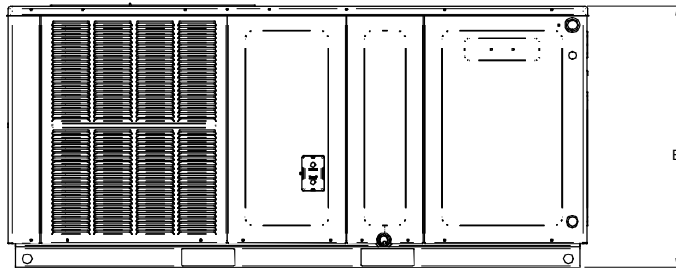

Chassis	Model	A	B
Small	GPH1324H41**	22.000	29.932
	GPH1330H41**	22.000	29.932
Medium	GPH1336H41**	24.000	34.932
	GPH1342H41**	24.000	34.932
Large	GPH1348H41**	24.000	38.682
	GPH1360H41**	24.000	38.682

PACKAGE HEAT PUMP SPECIFICATIONS

GPH13[24-36]H41AB
GPH1336H41AC

		GPH1324H41**	GPH1330H41**	GPH1336H41**
COOLING CAPACITY	COOLING CAPACITY, BTUH	24,000	28,200	35,000
	SEER	13.00	13.00	13.00
HEATING RATING	47°/43°F	22,000	27,000	33,600
	35°/33°F	17,600	20,400	27,000
	17°/15°F	14,000	15,000	18,000
	HSPF	7.7	7.7	7.7
UNIT ELECTRICAL SPECIFICATION	VOLTAGE (NAMEPLATE)	208/230-60-1	208/230-60-1	208/230-60-1
	AMPS	15.4	17.06	20.06
	MIN CIRCUIT AMPACITY	18.6	20.6	24.2
	MAX OVERCURRENT PROTECTION ⁽²⁾	30	30	40
COMPRESSOR	TYPE	SCROLL	SCROLL	SCROLL
	RATED LOAD AMPS	12.8	14.1	16.7
	LOCKED ROTOR AMPS	58.3	73.0	79.0
CONDENSER FAN MOTOR	HORSEPOWER	1/6	1/6	1/4
	RPM	815	815	830
	FULL LOAD AMPS	1.1	1.1	1.5
	LOCKED ROTOR AMPS	1.7	1.7	3.0
CONDENSER FAN	BLADE DIAMETER (INCHES) / # OF BLADES	22 / 3	22 / 3	22 / 4
CONDENSER COIL	FACE AREA (SQ. FT.)	13.4	13.4	17
	NUMBER OF ROWS	1	1	1
	FINS PER INCH	24	24	24
EVAPORATOR BLOWER MOTOR	HORSEPOWER - NO. OF SPEEDS	1/4 - 3	1/3 - 3	1/3 - 3
	FULL LOAD AMPS	1.50	1.86	1.86
	LOCKED ROTOR AMPS	2.2	3.2	3.2
	MOTOR SPEED TAP - COOLING	MEDIUM	LOW	MEDIUM
	RPM	1,075	1,075	1,075
EVAPORATOR BLOWER	DIAMETER X WIDTH (INCHES)	9 x 6	9 x 6	9 x 8
	RATED SCFM COOLING	875	1,080	1,205
	MAX EXTERNAL STATIC PRESS ("w.c.)	0.5	0.5	0.5
EVAPORATOR COIL	FACE AREA (SQ. FT.)	4.6	4.6	5.2
	NUMBER OF ROWS	3	3	3
	FINS PER INCH	14	14	14
GENERAL INFORMATION	FILTER SIZE (SQ. FT.)	20 x 20 x 1	20 x 25 x 1	25 x 25 x 1
	DRAIN SIZE (INCHES)	3/4"	3/4"	3/4"
	EXPANSION DEVICE (INDOOR / OUTDOOR)	ORIFICE (0.057 / 0.049)	ORIFICE (0.065 / 0.055)	ORIFICE (0.068 / 0.065)
	REFRIGERANT CHARGE R-410A (OZS.)	115	140	125
	POWER SUPPLY CONDUIT KNOCKOUT SIZE (INCHES)	3/4, 1, 1-1/4	3/4, 1, 1-1/4	3/4, 1, 1-1/4
	LOW VOLTAGE CONDUIT KNOCKOUT SIZE (INCHES)	1/2	1/2	1/2
	LO PRESSURE SWITCH			
	OPENS / CLOSES PSIG	22 / 50	22 / 50	22 / 50
	HI PRESSURE SWITCH - OPENS PSIG			
	OPENS / CLOSES PSIG	660 / 420	660 / 420	660 / 420
	SHIPPING WEIGHT (LBS.)	325	325	385
OPERATING WEIGHT (LBS.)	315	315	375	

⁽²⁾ Maximum Overcurrent Protection Device: **MUST** use Time Delay Fuse or HACR type Circuit Breaker of the same size as noted.

* Calculated external filter size based on air velocity of 300 ft/min.

Wire size should be determined in accordance with National Electrical Codes. Extensive wire runs will require larger wire sizes.

Unit specifications are subject to change without notice. **ALWAYS** refer to the units serial plate for the most up-to-date general and electrical information.

IMPORTANT: While this data is presented as a guide, it is important to electrically connect the unit and properly size wires and fuses/circuit breakers in accordance with the National Electrical Code and/or all local codes. Data shown is w/o electric heaters.

PACKAGE HEAT PUMP SPECIFICATIONS

GPH1342H41AB
GPH13[48-60]H41BB

		GPH1342H41**	GPH1348H41**	GPH1360H41**
COOLING CAPACITY	COOLING CAPACITY, BTUH	40,500	46,000	57,500
	SEER	13.00	13.00	13.00
HEATING RATING	47°/43°F	38,000	44,500	54,400
	35°/33°F	30,000	33,000	39,000
	17°/15°F	21,800	26,000	32,000
	HSPF	7.8	7.7	7.7
UNIT ELECTRICAL SPECIFICATION	VOLTAGE (NAMEPLATE)	208/230-60-1	208/230-60-1	208/230-60-1
	AMPS	22.2	24.17	33.6
	MIN CIRCUIT AMPACITY	26.6	29.2	40.2
	MAX OVERCURRENT PROTECTION ⁽²⁾	40	45	60
COMPRESSOR	TYPE	SCROLL	SCROLL	SCROLL
	RATED LOAD AMPS	17.9	19.9	26.4
	LOCKED ROTOR AMPS	112	109	134
CONDENSER FAN MOTOR	HORSEPOWER	1/6	1/6	1/4
	RPM	1075	1075	1075
	FULL LOAD AMPS	1.4	1.4	1.4
	LOCKED ROTOR AMPS	2.9	2.9	2.9
CONDENSER FAN	BLADE DIAMETER (INCHES) / # OF BLADES	22 / 4	22 / 4	22 / 4
CONDENSER COIL	FACE AREA (SQ. FT.)	17	19.1	19.1
	NUMBER OF ROWS	1	2	2
	FINS PER INCH	24	16	16
EVAPORATOR BLOWER MOTOR	HORSEPOWER - NO. OF SPEEDS	1/2 - 3	1/2 - 3	3/4 - 3
	FULL LOAD AMPS	2.87	2.87	5.8
	LOCKED ROTOR AMPS	4.9	4.9	8.0
	MOTOR SPEED TAP - COOLING	MEDIUM	HIGH	MEDIUM
	RPM	1,075	1,075	1,075
EVAPORATOR BLOWER	DIAMETER X WIDTH (INCHES)	10 x 8	10 x 8	11 x 8
	RATED SCFM COOLING	1,410	1,585	1,850
	MAX EXTERNAL STATIC PRESS ("w.c.)	0.5	0.5	0.5
EVAPORATOR COIL	FACE AREA (SQ. FT.)	6.2	6.2	7.0
	NUMBER OF ROWS	4	4	4
	FINS PER INCH	14	14	14
GENERAL INFORMATION	FILTER SIZE (SQ. FT.)	(2) 20 x 20 x 1	(2) 20 x 20 x 1	(2) 20 x 25 x 1
	DRAIN SIZE (INCHES)	3/4"	3/4"	3/4"
	EXPANSION DEVICE (INDOOR / OUTDOOR)	ORIFICE (0.068 / 0.065)	ORIFICE (0.076 / 0.067)	ORIFICE (0.088 / 0.076)
	REFRIGERANT CHARGE R-410A (OZS.)	140	170	175
	POWER SUPPLY CONDUIT KNOCKOUT SIZE (INCHES)	3/4, 1, 1-1/4	3/4, 1, 1-1/4	3/4, 1, 1-1/4
	LOW VOLTAGE CONDUIT KNOCKOUT SIZE (INCHES)	1/2	1/2	1/2
	PRESSURE SWITCH - OPENS / CLOSES PSIG	7 / 25	7 / 25	7 / 25
	LO PRESSURE SWITCH OPENS / CLOSES PSIG	22 / 50	22 / 50	22 / 50
	HI PRESSURE SWITCH - OPENS PSIG OPENS / CLOSES PSIG	660 / 420	660 / 420	660 / 420
	SHIPPING WEIGHT (LBS.)	385	415	415
	OPERATING WEIGHT (LBS.)	375	405	405

⁽²⁾ Maximum Overcurrent Protection Device: **MUST** use Time Delay Fuse or HACR type Circuit Breaker of the same size as noted.
* Calculated external filter size based on air velocity of 300 ft/min.

Wire size should be determined in accordance with National Electrical Codes. Extensive wire runs will require larger wire sizes. Unit specifications are subject to change without notice. **ALWAYS** refer to the units serial plate for the most up-to-date general and electrical information.

IMPORTANT: While this data is presented as a guide, it is important to electrically connect the unit and properly size wires and fuses/circuit breakers in accordance with the National Electrical Code and/or all local codes. Data shown is w/o electric heaters.

ACCESSORIES

Part Number	Description
OT18-60A	Outdoor Thermostat Kit w/Lockout Stat
OT/EHR18-60	Emergency Heat Relay Kit
HKR	Electric Heat Kit
PCCP101-103	Roof Curb
PCP101-103	Downflow Plenum Kit
PCP101-103R8	Downflow Plenum Kit w/ R-8 Insulation
GPCED101-103	Downflow Economizer for GPC-(H) A/C - To Be Used With PCP101-103
GPHEH101-103	Downflow Economizer for GPH-(H) Heat Pump - To Be Used With PCP101-103
GPCEH101-103	Horizontal Economizer for GPC-(H) A/C
GPHEH101-103	Horizontal Economizer for GPH-(H) Heat Pump
PCMD101-103	Manual Damper - To Be Used With PCP101-103
PCMDM101-103	Motorized Damper - To Be Used With PCP101-103
GPHMD101-103	Manual Damper for Horizontal Applications
SQRPCH101	Square to Round Adapters 16"&14"
SQRPCH102-103	Square to Round Adapters 18"&14"
SQRPC101	Square to Round Adapter - For Use With PCCP101-103 Curb 16" Rounds
SQRPC102-103	Square to Round Adapter For Use With PCCP101-103 Curb 18" Rounds
PCFR101-103	External Horizontal Filter Rack
PCEF101-103	Elbow & Flashing w/ R-8 Liner
CDK36	Flush Mount Concentric Duct Kit
CDK36515	Flush Mount Concentric Duct Kit w/ Filter
CDK36530	Step Down Concentric Duct Kit
CDK36535	Step Down Concentric Duct Kit w/ Filter
CDK4872	Flush Mount Concentric Duct Kit
CDK4872515	Flush Mount Concentric Duct Kit w/ Filter
CDK4872530	Step Down Concentric Duct Kit
CDK4872535	Step Down Concentric Duct Kit w/ Filter

BLOWER PERFORMANCE DATA

GP H13[24-60]H41**

Dry Coil Data

Model	Speed	Volts	E.S.P (In. of H ₂ O)								
			0.1	0.2	0.3	0.4	0.5	0.6	0.7	0.8	
GP H1 324H41 **	LOW	230	CFM	680	640	590	555	505	440	340	-
			WATTS	155	150	145	140	130	120	110	-
	MED	230	CFM	895	855	815	755	700	630	545	390
			WATTS	230	220	215	205	195	180	170	145
	HIGH	230	CFM	1,185	1,130	1,070	1,010	930	850	760	650
			WATTS	350	340	325	310	295	280	265	245
GP H1 330H41 **	LOW	230	CFM	1,150	1,080	1,025	975	925	845	-	-
			WATTS	340	330	315	305	295	280	-	-
	MED	230	CFM	1,335	1,275	1,205	1,135	1,075	985	910	845
			WATTS	425	415	400	385	370	350	330	310
	HIGH	230	CFM	1,435	1,355	1,290	1,210	1,130	1,040	960	885
			WATTS	485	465	455	435	415	400	385	370
GP H1 336H41 **	LOW	230	CFM	1,180	1,125	1,075	1,020	955	875	655	-
			WATTS	335	325	315	305	295	275	240	-
	MED	230	CFM	1,350	1,280	1,205	1,130	1,050	985	910	845
			WATTS	435	420	405	385	375	350	330	310
	HIGH	230	CFM	1,450	1,370	1,290	1,205	1,130	1,040	960	885
			WATTS	495	480	465	440	425	400	385	370
GP H1 342H41 **	LOW	230	CFM	1,425	1,410	1,355	1,310	1,245	1,170	1,080	-
			WATTS	450	445	430	420	405	390	370	-
	MED	230	CFM	1,620	1,595	1,545	1,485	1,425	1,345	1,250	1,160
			WATTS	550	540	525	510	495	475	450	425
	HIGH	230	CFM	1,945	1,935	1,875	1,800	1,730	1,635	1,535	1,440
			WATTS	765	755	735	715	695	670	640	615
GP H1 348H41 **	LOW	230	CFM	1,425	1,410	1,355	1,310	1,245	1,170	1,080	-
			WATTS	450	445	430	420	405	390	370	-
	MED	230	CFM	1,720	1,660	1,585	1,520	1,460	1,365	1,270	-
			WATTS	560	555	540	530	520	490	470	-
	HIGH	230	CFM	2,110	2,060	1,980	1,895	1,795	1,705	1,590	1,500
			WATTS	785	780	765	745	720	705	665	625
GP H1 360H41 **	T1	230	CFM	1,775	1,635	1,645	1,515	1,510	1,450	1,430	1,400
			WATTS	395	420	435	445	455	465	470	475
	T2/T3	230	CFM	1,845	1,790	1,715	1,685	1,590	1,580	1,530	1,500
			WATTS	490	505	520	535	550	560	570	575
	T4/T5	230	CFM	2,025	1,900	1,840	1,780	1,725	1,650	1,620	1,580
			WATTS	575	595	620	630	645	655	660	670

NOTES:

1. Data shown is Dry Coil. Wet Coil Pressure Drop is approximate.
2. 0.1" H₂O, for 2 row indoor coil; 0.2" H₂O, for 3 row indoor coil; and 0.3" H₂O, for 4 row indoor coil.
3. Data shown does not include filter pressure drop, approx. 0.08" H₂O.
4. Reduce airflow by 2% for 208V operation.

BLOWER PERFORMANCE DATA

BTU OUTPUT vs TEMPERATURE RISE CHART

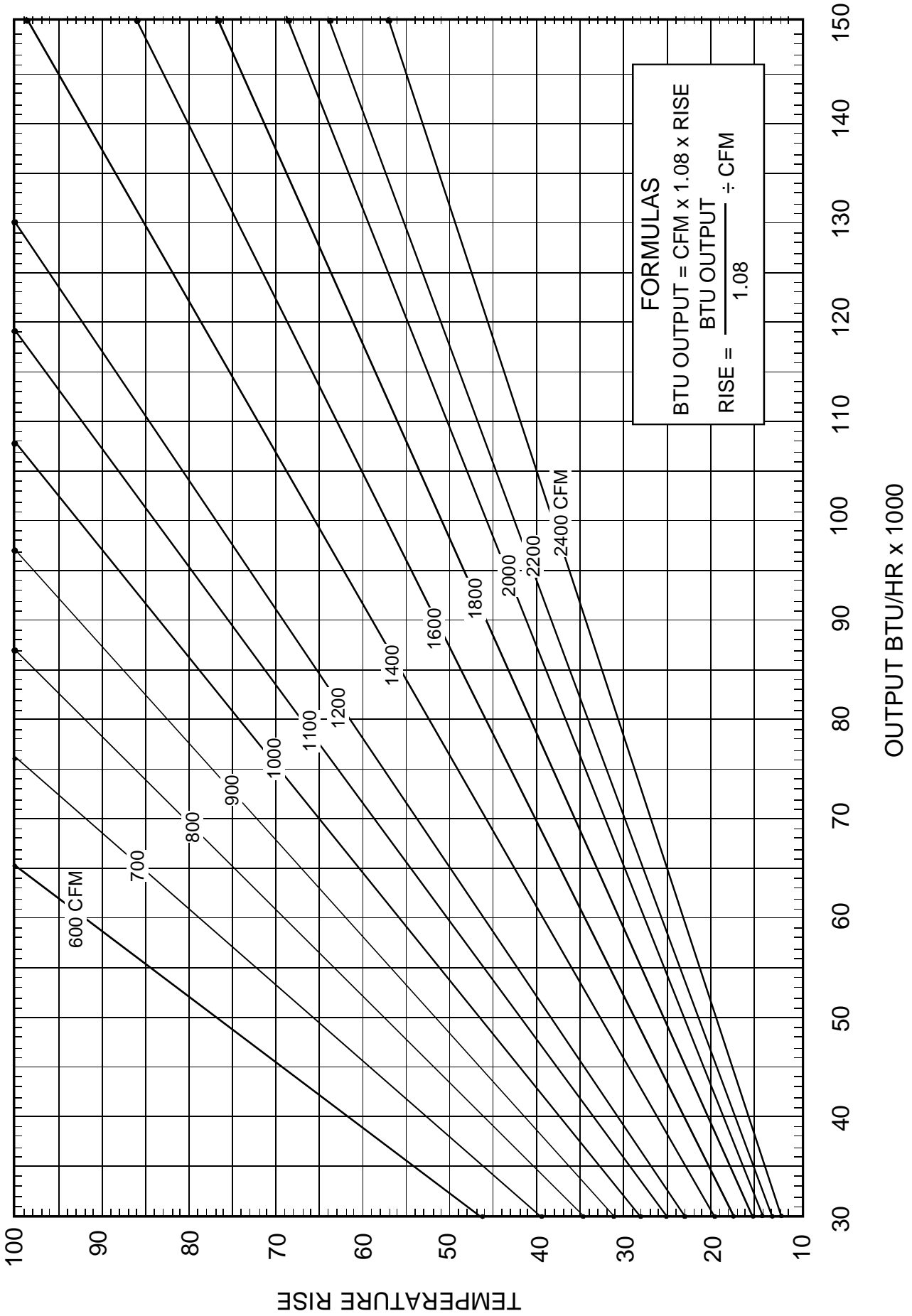

COOLING PERFORMANCE DATA

GPH1324H41**

EXPANDED PERFORMANCE DATA

EXPANDED PERFORMANCE DATA

MODEL: GPH1324H41**

Design Subcooling, 12±3 °F @ the liquid access fitting connection AHRI 95 test conditions. Design Superheat 8±3 °F @ the compressor suction access fitting connection.

IDB*	Airflow	Outdoor Ambient Temperature												Cooling Operation																																																																																																																																																																																																																																																																																																																																																																																																																																																																																																																
		65						75						85						95						105						115																																																																																																																																																																																																																																																																																																																																																																																																																																																																																														
		59	63	67	71	75	79	59	63	67	71	75	79	59	63	67	71	75	79	59	63	67	71	75	79	59	63	67	71	75	79	59	63	67	71	75	79																																																																																																																																																																																																																																																																																																																																																																																																																																																																																									
70	980	MBh	23.5	24.4	26.7	-	23.0	23.8	26.1	-	22.4	23.2	25.5	-	21.9	22.7	24.8	-	20.8	21.5	23.6	-	19.3	20.0	21.9	-	0.80	0.87	0.46	-	0.85	0.71	0.49	-	0.88	0.73	0.51	-	0.91	0.76	0.53	-	17	14	11	-	1.71	1.74	1.80	-	1.83	1.87	1.93	-	1.95	1.99	2.05	-	2.05	2.09	2.16	-	2.13	2.18	2.25	-	2.20	2.25	2.32	-	7.2	7.4	7.6	-	7.7	7.9	8.1	-	8.3	8.5	8.8	-	8.8	9.0	9.3	-	9.3	9.5	9.8	-	9.8	10.0	10.3	-	242	260	275	-	271	292	308	-	308	332	350	-	351	378	399	-	395	425	449	-	436	470	496	-	112	119	130	-	118	126	137	-	123	131	143	-	129	137	150	-	135	144	157	-	140	149	163	-	22.8	23.7	25.9	-	22.3	23.1	25.3	-	21.8	22.6	24.7	-	21.2	22.0	24.1	-	20.2	20.9	22.9	-	18.7	19.4	21.2	-	0.76	0.64	0.44	-	0.79	0.68	0.46	-	0.81	0.68	0.47	-	0.84	0.70	0.49	-	0.87	0.73	0.50	-	0.88	0.73	0.51	-	1.69	1.73	1.78	-	1.82	1.86	1.92	-	1.93	1.97	2.03	-	2.03	2.07	2.14	-	2.11	2.16	2.23	-	2.18	2.23	2.31	-	7.2	7.3	7.5	-	7.7	7.8	8.1	-	8.3	8.4	8.7	-	8.8	8.9	9.2	-	9.3	9.5	9.7	-	9.7	10.0	10.3	-	239	257	272	-	268	289	305	-	305	328	347	-	348	374	395	-	391	421	444	-	432	465	491	-	111	118	129	-	117	125	136	-	122	130	141	-	128	136	149	-	134	143	156	-	139	148	161	-	21.7	22.5	24.6	-	21.2	22.0	24.1	-	20.7	21.4	23.5	-	20.2	20.9	22.9	-	19.2	19.9	21.8	-	17.8	18.4	20.2	-	0.73	0.61	0.42	-	0.76	0.63	0.44	-	0.78	0.65	0.45	-	0.80	0.67	0.46	-	0.83	0.70	0.48	-	0.84	0.70	0.49	-	1.9	1.6	1.2	-	1.9	1.7	1.3	-	1.9	1.7	1.3	-	1.9	1.7	1.3	-	1.9	1.7	1.3	-	1.8	1.6	1.2	-	1.67	1.70	1.75	-	1.79	1.83	1.89	-	1.90	1.94	2.00	-	2.00	2.04	2.10	-	2.08	2.12	2.19	-	2.15	2.20	2.27	-	7.1	7.2	7.4	-	7.6	7.7	7.9	-	8.1	8.3	8.5	-	8.6	8.8	9.1	-	9.1	9.3	9.6	-	9.6	9.8	10.1	-	234	252	266	-	263	283	299	-	299	322	340	-	341	367	387	-	383	412	436	-	423	456	481	-	109	116	126	-	115	122	133	-	119	127	139	-	125	133	146	-	131	140	153	-	136	145	158	-																																																								
		980	MBh	23.9	24.6	26.7	28.6	23.4	24.1	26.0	27.9	22.8	23.5	25.4	27.3	22.2	22.9	24.8	26.6	21.1	21.8	23.6	25.3	19.6	20.2	21.8	23.4	0.91	0.81	0.62	0.40	0.94	0.84	0.64	0.41	0.97	0.87	0.66	0.42	1.00	0.89	0.68	0.44	1.00	0.93	0.70	0.45	1.00	0.94	0.71	0.46	20	19	15	11	21	19	16	11	21	19	16	11	21	19	16	11	21	19	16	11	20	19	16	11	10	1.72	1.76	1.81	1.87	1.85	1.89	1.95	2.01	1.96	2.00	2.07	2.13	2.06	2.11	2.17	2.25	2.15	2.19	2.27	2.34	2.22	2.27	2.34	2.42	7.3	7.5	7.7	7.9	7.8	8.0	8.2	8.5	8.4	8.6	8.8	9.1	8.9	9.1	9.4	9.7	9.4	9.6	9.9	10.2	9.9	10.1	10.4	10.8	244	263	277	289	274	295	311	325	311	335	354	369	355	382	403	420	399	429	453	473	441	474	501	523	113	120	131	140	120	127	139	148	124	132	144	154	131	139	152	161	137	146	159	169	142	151	164	175	23.2	23.9	25.9	27.8	22.7	23.4	25.3	27.1	22.1	22.8	24.7	26.5	21.6	22.2	24.1	25.8	20.5	21.1	22.9	24.5	19.0	19.6	21.2	22.7	0.87	0.78	0.59	0.38	0.90	0.81	0.61	0.39	0.92	0.83	0.63	0.40	0.95	0.85	0.65	0.42	0.99	0.88	0.67	0.43	1.00	0.89	0.68	0.43	21	20	16	11	21	20	16	11	21	20	16	11	22	20	16	11	22	20	16	11	21	20	16	11	10	1.71	1.74	1.80	1.85	1.83	1.87	1.93	1.99	1.95	1.99	2.05	2.12	2.05	2.09	2.16	2.23	2.13	2.18	2.25	2.32	2.20	2.25	2.32	2.40	7.2	7.4	7.6	7.8	7.7	7.9	8.1	8.4	8.3	8.5	8.8	9.0	8.8	9.0	9.3	9.6	9.3	9.5	9.8	10.2	9.8	10.0	10.3	10.7	242	260	275	286	271	292	308	321	308	332	350	365	351	378	399	416	395	425	449	468	437	470	496	517	112	119	130	139	118	126	138	146	123	131	143	152	129	138	150	160	135	144	157	168	140	149	163	173	22.1	22.7	24.6	26.4	21.5	22.2	24.0	25.8	21.0	21.7	23.4	25.2	20.5	21.1	22.9	24.5	19.5	20.1	21.7	23.3	18.1	18.6	20.1	21.6	0.83	0.74	0.56	0.36	0.86	0.77	0.58	0.38	0.88	0.79	0.60	0.39	0.91	0.82	0.62	0.40	0.95	0.85	0.64	0.41	0.96	0.85	0.65	0.42	22	20	17	11	22	20	17	12	22	20	17	12	22	21	17	12	22	20	17	12	21	20	17	11	10	1.68	1.72	1.77	1.82	1.81	1.84	1.90	1.96	1.92	1.96	2.02	2.08	2.01	2.06	2.12	2.19	2.10	2.14	2.21	2.28	2.17	2.21	2.29	2.36	7.1	7.3	7.5	7.7	7.6	7.8	8.0	8.3	8.2	8.4	8.6	8.9	8.7	8.9	9.1	9.4	9.2	9.4	9.7	10.0	9.7	9.9	10.2	10.5	237	255	269	281	266	286	302	315	302	325	343	358	344	370	391	408	387	417	440	459	428	460	486	507	110	117	128	136	116	123	135	144	121	128	140	149	127	135	147	157	133	141	154	164	137	146	159	170
			875	MBh	23.9	24.6	26.7	28.6	23.4	24.1	26.0	27.9	22.8	23.5	25.4	27.3	22.2	22.9	24.8	26.6	21.1	21.8	23.6	25.3	19.6	20.2	21.8	23.4	0.91	0.81	0.62	0.40	0.94	0.84	0.64	0.41	0.97	0.87	0.66	0.42	1.00	0.89	0.68	0.44	1.00	0.93	0.70	0.45	1.00	0.94	0.71	0.46	20	19	15	11	21	19	16	11	21	19	16	11	21	19	16	11	21	19	16	11	20	19	16	11	10	1.72	1.76	1.81	1.87	1.85	1.89	1.95	2.01	1.96	2.00	2.07	2.13	2.06	2.11	2.17	2.25	2.15	2.19	2.27	2.34	2.22	2.27	2.34	2.42	7.3	7.5	7.7	7.9	7.8	8.0	8.2	8.5	8.4	8.6	8.8	9.1	8.9	9.1	9.4	9.7	9.4	9.6	9.9	10.2	9.9	10.1	10.4	10.8	244	263	277	289	274	295	311	325	311	335	354	369	355	382	403	420	399	429	453	473	441	474	501	523	113	120	131	140	120	127	139	148	124	132	144	154	131	139	152	161	137	146	159	169	142	151	164	175	23.2	23.9	25.9	27.8	22.7	23.4	25.3	27.1	22.1	22.8	24.7	26.5	21.6	22.2	24.1	25.8	20.5	21.1	22.9	24.5	19.0	19.6	21.2	22.7	0.87	0.78	0.59	0.38	0.90	0.81	0.61	0.39	0.92	0.83	0.63	0.40	0.95	0.85	0.65	0.42	0.99	0.88	0.67	0.43	1.00	0.89	0.68	0.43	21	20	16	11	21	20	16	11	21	20	16	11	22	20	16	11	22	20	16	11	21	20	16	11	10	1.71	1.74	1.80	1.85	1.83	1.87	1.93	1.99	1.95	1.99	2.05	2.12	2.05	2.09	2.16	2.23	2.13	2.18	2.25	2.32	2.20	2.25	2.32	2.40	7.2	7.4	7.6	7.8	7.7	7.9	8.1	8.4	8.3	8.5	8.8	9.0	8.8	9.0	9.3	9.6	9.3	9.5	9.8	10.2	9.8	10.0	10.3	10.7	242	260	275	286	271	292	308	321	308	332	350	365	351	378	399	416	395	425	449	468	437	470	496	517	112	119	130	139	118	126	138	146	123	131	143	152	129	138	150	160	135	144	157	168	140	149	163	173	22.1	22.7	24.6	26.4	21.5	22.2	24.0	25.8	21.0	21.7	23.4	25.2	20.5	21.1	22.9	24.5	19.5	20.1	21.7	23.3	18.1	18.6	20.1	21.6	0.83	0.74	0.56	0.36	0.86	0.77	0.58	0.38	0.88	0.79	0.60	0.39	0.91	0.82	0.62	0.40	0.95	0.85	0.64	0.41	0.96	0.85	0.65	0.42	22	20	17	11	22	20	17	12	22	20	17	12	22	21	17	12	22	20	17	12	21	20	17	11	10	1.68	1.72	1.77	1.82	1.81	1.84	1.90	1.96	1.92	1.96	2.02	2.08	2.01	2.06	2.12	2.19	2.10	2.14	2.21	2.28	2.17	2.21	2.29	2.36	7.1	7.3	7.5	7.7	7.6	7.8	8.0	8.3	8.2	8.4	8.6	8.9	8.7	8.9	9.1	9.4	9.2	9.4	9.7	10.0	9.7	9.9	10.2	10.5	237	255																																													

Design Subcooling, 12±3 °F @ the liquid access fitting connection AHRI 95 test conditions. Design Superheat 8±3 °F @ the compressor suction access fitting connection.

IDB*	Airflow	Outdoor Ambient Temperature																								
		65				75				85				95				105				115				
		59	63	67	71	59	63	67	71	59	63	67	71	59	63	67	71	59	63	67	71	59	63	67	71	
80	980	MBh	24.3	24.9	26.6	28.4	23.8	24.3	26.0	27.7	23.2	23.7	25.3	27.1	22.6	23.1	24.7	26.4	21.5	22.0	23.5	25.1	19.9	20.4	21.8	23.3
		S/T	1.00	0.94	0.76	0.57	1.00	1.00	0.79	0.59	1.00	1.00	0.81	0.61	1.00	1.00	0.84	0.63	1.00	1.00	0.87	0.65	1.00	1.00	0.88	0.65
		Delta T	23	22	19	15	22	23	19	15	22	22	19	15	21	22	19	16	20	21	19	15	19	19	18	14
		KW	1.73	1.77	1.82	1.88	1.86	1.90	1.96	2.03	1.98	2.02	2.08	2.15	2.08	2.12	2.19	2.26	2.17	2.21	2.28	2.36	2.24	2.29	2.36	2.44
		AMPS	7.4	7.5	7.7	8.0	7.9	8.0	8.3	8.5	8.5	8.6	8.9	9.2	9.0	9.2	9.4	9.8	9.5	9.7	10.0	10.3	10.0	10.2	10.5	10.9
		H1PR	246	265	280	292	277	298	314	328	315	339	357	373	358	386	407	425	403	434	458	478	445	479	506	528
		LO PR	114	122	133	141	121	129	140	149	126	134	146	155	132	140	153	163	138	147	161	171	143	152	166	177
		MBh	23.6	24.1	25.8	27.6	23.1	23.6	25.2	26.9	22.5	23.0	24.6	26.3	22.0	22.5	24.0	25.7	20.9	21.3	22.8	24.4	19.3	19.8	21.1	22.6
		S/T	0.95	0.89	0.73	0.54	0.99	0.93	0.75	0.56	1.00	0.95	0.77	0.58	1.00	0.98	0.80	0.60	1.00	1.00	0.83	0.62	1.00	1.00	0.84	0.62
		Delta T	24	23	20	16	24	23	20	16	24	23	20	16	23	23	20	16	22	22	20	16	20	21	19	15
KW	1.72	1.76	1.81	1.87	1.85	1.89	1.95	2.01	1.96	2.00	2.07	2.14	2.06	2.11	2.18	2.25	2.15	2.19	2.27	2.34	2.22	2.27	2.34	2.42		
AMPS	7.3	7.5	7.7	7.9	7.8	8.0	8.2	8.5	8.4	8.6	8.8	9.1	8.9	9.1	9.4	9.7	9.4	9.6	9.9	10.2	9.9	10.1	10.4	10.8		
H1PR	244	263	277	289	274	295	311	325	311	335	354	369	355	382	403	420	399	429	453	473	441	474	501	523		
LO PR	113	120	131	140	120	127	139	148	124	132	144	154	131	139	152	162	137	146	159	169	142	151	164	175		
MBh	22.5	22.9	24.5	26.2	21.9	22.4	23.9	25.6	21.4	21.9	23.4	25.0	20.9	21.3	22.8	24.4	19.8	20.3	21.7	23.2	18.4	18.8	20.1	21.4		
S/T	0.91	0.86	0.70	0.52	0.95	0.89	0.72	0.54	0.97	0.91	0.74	0.55	1.00	0.94	0.76	0.57	1.04	0.97	0.79	0.59	1.05	0.98	0.80	0.60		
Delta T	24	23	20	16	25	24	21	16	25	24	21	17	25	24	21	17	25	24	21	16	23	22	19	15		
KW	1.69	1.73	1.78	1.84	1.82	1.86	1.92	1.98	1.93	1.97	2.03	2.10	2.03	2.07	2.14	2.21	2.11	2.16	2.23	2.30	2.18	2.23	2.31	2.38		
AMPS	7.2	7.3	7.5	7.8	7.7	7.8	8.1	8.3	8.3	8.4	8.7	9.0	8.8	8.9	9.2	9.5	9.2	9.5	9.7	10.1	9.7	10.0	10.3	10.6		
H1PR	239	257	272	283	268	289	305	318	305	328	347	362	348	374	395	412	391	421	444	464	432	465	491	512		
LO PR	111	118	129	137	117	125	136	145	122	130	141	151	128	136	149	158	134	143	156	166	139	148	161	172		

85	980	MBh	24.8	25.2	26.4	28.2	24.2	24.7	25.8	27.6	23.6	24.1	25.2	26.9	23.0	23.5	24.6	26.2	21.9	22.3	23.4	24.9	20.3	20.7	21.6	23.1
		S/T	1.00	1.00	0.91	0.74	1.00	1.00	0.95	0.77	1.00	1.00	0.97	0.79	1.00	1.00	0.81	0.81	1.00	1.00	0.84	1.00	1.00	0.88	0.81	0.85
		Delta T	23	24	23	20	23	23	23	20	22	23	23	20	22	22	23	20	21	21	22	20	19	19	20	18
		KW	1.75	1.78	1.84	1.90	1.88	1.92	1.98	2.04	1.99	2.04	2.10	2.17	2.10	2.14	2.21	2.28	2.18	2.23	2.30	2.38	2.26	2.31	2.38	2.46
		AMPS	7.4	7.6	7.8	8.0	7.9	8.1	8.3	8.6	8.5	8.7	9.0	9.3	9.0	9.2	9.5	9.8	9.6	9.8	10.1	10.4	10.1	10.3	10.6	11.0
		H1PR	249	268	283	295	279	301	317	331	318	342	361	377	362	389	411	429	407	438	463	482	450	484	511	533
		LO PR	115	123	134	143	122	130	142	151	127	135	147	157	133	142	155	165	140	149	162	173	144	154	168	179
		MBh	24.0	24.5	25.7	27.4	23.5	23.9	25.1	26.8	22.9	23.4	24.5	26.1	22.4	22.8	23.9	25.5	21.2	21.7	22.7	24.2	19.7	20.1	21.0	22.4
		S/T	1.00	0.96	0.87	0.71	1.00	1.00	0.90	0.73	1.00	1.00	0.92	0.75	1.00	1.00	0.81	0.77	1.00	1.00	0.99	0.80	1.00	1.00	0.88	0.81
		Delta T	25	25	23	20	25	25	24	21	24	25	24	21	24	24	24	21	22	23	24	20	21	21	22	19
KW	1.73	1.77	1.82	1.88	1.86	1.90	1.96	2.03	1.98	2.02	2.08	2.15	2.08	2.12	2.19	2.26	2.17	2.21	2.28	2.36	2.24	2.29	2.36	2.44		
AMPS	7.4	7.5	7.7	8.0	7.9	8.0	8.3	8.5	8.5	8.6	8.9	9.2	9.0	9.2	9.4	9.8	9.5	9.7	10.0	10.3	10.0	10.2	10.5	10.9		
H1PR	246	265	280	292	277	298	314	328	315	339	357	373	358	386	407	425	403	434	458	478	445	479	506	528		
LO PR	114	122	133	141	121	129	140	149	126	134	146	155	132	140	153	163	138	147	161	171	143	152	166	177		
MBh	22.8	23.3	24.4	26.0	22.3	22.7	23.8	25.4	21.8	22.2	23.3	24.8	21.2	21.7	22.7	24.2	20.2	20.6	21.6	23.0	18.7	19.1	20.0	21.3		
S/T	0.96	0.92	0.83	0.68	0.99	0.96	0.86	0.70	1.00	0.98	0.89	0.72	1.00	1.00	0.91	0.74	1.00	1.00	0.95	0.77	1.00	1.00	0.96	0.78		
Delta T	26	26	24	21	26	26	25	21	26	26	25	21	25	26	25	21	25	26	25	21	24	25	23	20		
KW	1.71	1.74	1.80	1.85	1.83	1.87	1.93	1.99	1.95	1.99	2.05	2.12	2.05	2.09	2.16	2.23	2.13	2.18	2.25	2.32	2.20	2.25	2.32	2.40		
AMPS	7.2	7.4	7.6	7.8	7.7	7.9	8.1	8.4	8.3	8.5	8.8	9.0	8.8	9.0	9.3	9.6	9.3	9.5	9.8	10.2	9.8	10.0	10.3	10.7		
H1PR	242	260	275	286	271	292	308	321	308	332	350	365	351	378	399	416	395	425	449	468	436	470	496	517		
LO PR	112	119	130	139	118	126	137	146	123	131	143	152	129	137	150	160	135	144	157	168	140	149	163	173		

* Entering Indoor Dry Bulb Temperature
 High and low pressures are measured at the liquid and suction access fittings.
 NOTE: Shaded area is AHRI Rating Conditions
 KW = Total system power
 AMPS: Unit amps (comp.+ evaporator + condenser fan motors)

COOLING PERFORMANCE DATA

GPH1330H41**

EXPANDED PERFORMANCE DATA

MODEL: GPH1330H41**

COOLING OPERATION

Design Subcooling, 12±3 °F @ the liquid access fitting connection AHRI 95 test conditions. Design Superheat 8±3 °F @ the compressor suction access fitting connection.

IDB*	Airflow	Outdoor Ambient Temperature																								
		65				75				85				95				105				115				
		59	63	67	71	59	63	67	71	59	63	67	71	59	63	67	71	59	63	67	71	59	63	67	71	
70	1180	MBh	27.6	28.6	31.4	-	27.0	28.0	30.7	-	26.3	27.3	29.9	-	25.7	26.6	29.2	-	24.4	25.3	27.7	-	22.6	23.4	25.7	-
		S/T	0.80	0.67	0.46	-	0.83	0.69	0.48	-	0.85	0.71	0.49	-	0.87	0.73	0.51	-	0.91	0.76	0.52	-	0.91	0.76	0.53	-
		Delta T	17	15	11	-	17	15	11	-	17	15	11	-	18	15	11	-	17	15	11	-	16	14	11	-
		KW	2.03	2.07	2.13	-	2.18	2.22	2.29	-	2.31	2.36	2.43	-	2.43	2.48	2.56	-	2.53	2.58	2.66	-	2.61	2.67	2.75	-
		AMPS	8.7	8.8	9.1	-	9.3	9.4	9.7	-	9.9	10.1	10.4	-	10.5	10.8	11.1	-	11.1	11.4	11.7	-	11.7	12.0	12.3	-
	1050	HIPR	247	265	280	-	277	298	314	-	315	339	358	-	358	386	407	-	403	434	458	-	446	479	506	-
		LO PR	112	119	130	-	118	126	137	-	123	131	143	-	129	137	150	-	135	144	157	-	140	149	162	-
		MBh	26.8	27.8	30.5	-	26.2	27.2	29.8	-	25.6	26.5	29.0	-	25.0	25.9	28.3	-	23.7	24.6	26.9	-	22.0	22.8	24.9	-
		S/T	0.76	0.63	0.44	-	0.79	0.66	0.46	-	0.81	0.67	0.47	-	0.83	0.70	0.48	-	0.87	0.72	0.50	-	0.87	0.73	0.50	-
		Delta T	18	15	12	-	18	16	12	-	18	16	12	-	18	16	12	-	18	16	12	-	17	15	11	-
920	1180	KW	2.01	2.05	2.12	-	2.16	2.21	2.27	-	2.29	2.34	2.41	-	2.41	2.46	2.54	-	2.51	2.56	2.64	-	2.59	2.65	2.73	-
		AMPS	8.6	8.8	9.0	-	9.2	9.4	9.6	-	9.9	10.1	10.4	-	10.4	10.7	11.0	-	11.0	11.3	11.6	-	11.6	11.9	12.2	-
		HIPR	244	263	277	-	274	295	311	-	312	335	354	-	355	382	403	-	399	430	454	-	441	475	501	-
		LO PR	111	118	129	-	117	124	136	-	121	129	141	-	128	136	148	-	134	142	155	-	138	147	161	-
		MBh	24.8	25.7	28.1	-	24.2	25.1	27.5	-	23.6	24.5	26.8	-	23.0	23.9	26.2	-	21.9	22.7	24.9	-	20.3	21.0	23.0	-
	1050	S/T	0.73	0.61	0.42	-	0.76	0.63	0.44	-	0.78	0.65	0.45	-	0.80	0.67	0.47	-	0.83	0.70	0.48	-	0.84	0.70	0.49	-
		Delta T	18	16	12	-	18	16	12	-	18	16	12	-	18	16	12	-	18	16	12	-	17	15	11	-
		KW	1.97	2.01	2.07	-	2.11	2.15	2.22	-	2.24	2.28	2.36	-	2.35	2.40	2.48	-	2.45	2.50	2.58	-	2.53	2.58	2.66	-
		AMPS	8.4	8.6	8.8	-	9.0	9.1	9.4	-	9.6	9.8	10.1	-	10.2	10.4	10.7	-	10.8	11.0	11.3	-	11.3	11.6	11.9	-
		HIPR	237	255	269	-	266	286	302	-	302	325	343	-	344	370	391	-	387	417	440	-	428	460	486	-
75	1180	LO PR	107	114	125	-	113	121	132	-	118	125	137	-	124	132	144	-	130	138	151	-	134	143	156	-
		MBh	28.1	28.9	31.3	33.6	27.4	28.3	30.6	32.8	26.8	27.6	29.9	32.0	26.1	26.9	29.1	31.3	24.8	25.6	27.7	29.7	23.0	23.7	25.6	27.5
		S/T	0.91	0.81	0.61	0.39	0.94	0.84	0.64	0.41	0.96	0.86	0.65	0.42	0.99	0.89	0.67	0.43	1.00	0.92	0.70	0.45	1.00	0.93	0.70	0.45
		Delta T	20	18	15	10	20	18	15	10	20	19	15	10	20	19	15	10	19	18	15	10	18	17	14	10
		KW	2.04	2.09	2.15	2.22	2.20	2.24	2.31	2.38	2.33	2.38	2.45	2.53	2.45	2.50	2.58	2.66	2.55	2.60	2.69	2.77	2.63	2.69	2.78	2.87
	1050	AMPS	8.7	8.9	9.1	9.4	9.3	9.5	9.8	10.1	10.0	10.2	10.5	10.9	10.6	10.8	11.2	11.5	11.2	11.5	11.8	12.2	11.8	12.1	12.4	12.9
		HIPR	249	268	283	295	280	301	318	331	318	342	361	377	362	390	411	429	407	438	463	483	450	484	511	533
		LO PR	113	120	131	140	119	127	139	148	124	132	144	153	130	139	151	161	136	145	158	169	141	150	164	175
		MBh	27.3	28.1	30.4	32.6	26.6	27.4	29.7	31.9	26.0	26.8	29.0	31.1	25.4	26.1	28.3	30.4	24.1	24.8	26.9	28.8	22.3	23.0	24.9	26.7
		S/T	0.86	0.77	0.58	0.38	0.90	0.80	0.61	0.39	0.92	0.82	0.62	0.40	0.95	0.85	0.64	0.41	0.98	0.88	0.67	0.43	0.99	0.89	0.67	0.43
920	1180	Delta T	21	19	16	11	21	19	16	11	21	19	16	11	21	19	16	11	21	19	16	11	21	19	16	11
		KW	2.03	2.07	2.13	2.20	2.18	2.22	2.29	2.36	2.31	2.36	2.43	2.51	2.43	2.48	2.56	2.64	2.53	2.58	2.66	2.75	2.61	2.67	2.76	2.85
		AMPS	8.7	8.8	9.1	9.4	9.3	9.4	9.7	10.0	9.9	10.1	10.4	10.8	10.5	10.8	11.1	11.4	11.1	11.4	11.7	12.1	11.7	12.0	12.3	12.7
		HIPR	247	265	280	292	277	298	315	328	315	339	358	373	358	386	407	425	403	434	458	478	446	480	506	528
		LO PR	112	119	130	138	118	126	137	146	123	131	143	152	129	137	150	159	135	144	157	167	140	149	162	173
	1050	MBh	25.2	25.9	28.1	30.1	24.6	25.3	27.4	29.4	24.0	24.7	26.8	28.7	23.4	24.1	26.1	28.0	22.3	22.9	24.8	26.6	20.6	21.2	23.0	24.7
		S/T	0.83	0.74	0.56	0.36	0.86	0.77	0.58	0.38	0.89	0.79	0.60	0.39	0.91	0.82	0.62	0.40	0.95	0.85	0.64	0.41	0.96	0.86	0.65	0.42
		Delta T	21	19	16	11	21	20	16	11	21	20	16	11	21	20	16	11	21	20	16	11	21	20	18	15
		KW	1.98	2.02	2.08	2.15	2.13	2.17	2.24	2.31	2.26	2.30	2.37	2.45	2.37	2.42	2.50	2.58	2.47	2.52	2.60	2.68	2.55	2.60	2.69	2.78
		AMPS	8.5	8.6	8.9	9.1	9.0	9.2	9.5	9.8	9.7	9.9	10.2	10.5	10.3	10.5	10.8	11.2	10.9	11.1	11.4	11.8	11.4	11.7	12.0	12.4
920	HIPR	239	257	272	284	268	289	305	318	305	329	347	362	348	374	395	412	391	421	445	464	432	465	491	512	
	LO PR	108	115	126	134	115	122	133	142	119	127	138	147	125	133	145	155	131	139	152	162	136	144	157	168	

* Entering Indoor Dry Bulb Temperature

NOTE: Shaded area is ACOA (TVA) conditions

High and low pressures are measured at the liquid and suction access fittings.

Design Subcooling, 12.3 °F @ the liquid access fitting connection AHRI 95 test conditions. Design Superheat 8.3 °F @ the compressor suction access fitting connection.

IDB*	Airflow	65												75												85												95												105												115																																																																																																																																																																																																																																																																																																																																																																																																																																																																																																																																																																																																																																																																																																																																																																																																																																																																																																																																																																																																																																																																																																																
		59				63				67				71				59				63				67				71				59				63				67				71				59				63				67				71																																																																																																																																																																																																																																																																																																																																																																																																																																																																																																																																																																																																																																																																																																																																																																																																																																																																																																																																																																																																																																																																																																																
		Entering Indoor Wet Bulb Temperature												Entering Indoor Wet Bulb Temperature												Entering Indoor Wet Bulb Temperature												Entering Indoor Wet Bulb Temperature												Entering Indoor Wet Bulb Temperature												Entering Indoor Wet Bulb Temperature																																																																																																																																																																																																																																																																																																																																																																																																																																																																																																																																																																																																																																																																																																																																																																																																																																																																																																																																																																																																																																																																																																																
80	1180	MBh	28.6	29.2	31.2	33.4	27.9	28.5	30.5	32.6	27.3	27.9	29.8	31.8	26.6	27.2	29.0	31.1	25.3	25.8	27.6	29.5	23.4	23.9	25.6	27.3	21.0	21.5	23.2	25.0	18.7	19.2	20.9	22.7	16.4	16.9	18.6	20.4	14.1	14.6	16.3	18.1	11.8	12.3	14.0	15.8	9.5	10.0	11.7	13.5	7.2	7.7	9.4	11.2	4.9	5.4	7.1	8.9	2.6	3.1	4.8	6.6	0.3	0.8	2.5	4.3	-1.9	-1.4	0.3	2.1	3.9	5.7	7.5	9.3	11.1	12.9	14.7	16.5	18.3	20.1	21.9	23.7	25.5	27.3	29.1	30.9	32.7	34.5	36.3	38.1	39.9	41.7	43.5	45.3	47.1	48.9	50.7	52.5	54.3	56.1	57.9	59.7	61.5	63.3	65.1	66.9	68.7	70.5	72.3	74.1	75.9	77.7	79.5	81.3	83.1	84.9	86.7	88.5	90.3	92.1	93.9	95.7	97.5	99.3	101.1	102.9	104.7	106.5	108.3	110.1	111.9	113.7	115.5	117.3	119.1	120.9	122.7	124.5	126.3	128.1	129.9	131.7	133.5	135.3	137.1	138.9	140.7	142.5	144.3	146.1	147.9	149.7	151.5	153.3	155.1	156.9	158.7	160.5	162.3	164.1	165.9	167.7	169.5	171.3	173.1	174.9	176.7	178.5	180.3	182.1	183.9	185.7	187.5	189.3	191.1	192.9	194.7	196.5	198.3	200.1	201.9	203.7	205.5	207.3	209.1	210.9	212.7	214.5	216.3	218.1	219.9	221.7	223.5	225.3	227.1	228.9	230.7	232.5	234.3	236.1	237.9	239.7	241.5	243.3	245.1	246.9	248.7	250.5	252.3	254.1	255.9	257.7	259.5	261.3	263.1	264.9	266.7	268.5	270.3	272.1	273.9	275.7	277.5	279.3	281.1	282.9	284.7	286.5	288.3	290.1	291.9	293.7	295.5	297.3	299.1	300.9	302.7	304.5	306.3	308.1	309.9	311.7	313.5	315.3	317.1	318.9	320.7	322.5	324.3	326.1	327.9	329.7	331.5	333.3	335.1	336.9	338.7	340.5	342.3	344.1	345.9	347.7	349.5	351.3	353.1	354.9	356.7	358.5	360.3	362.1	363.9	365.7	367.5	369.3	371.1	372.9	374.7	376.5	378.3	380.1	381.9	383.7	385.5	387.3	389.1	390.9	392.7	394.5	396.3	398.1	399.9	401.7	403.5	405.3	407.1	408.9	410.7	412.5	414.3	416.1	417.9	419.7	421.5	423.3	425.1	426.9	428.7	430.5	432.3	434.1	435.9	437.7	439.5	441.3	443.1	444.9	446.7	448.5	450.3	452.1	453.9	455.7	457.5	459.3	461.1	462.9	464.7	466.5	468.3	470.1	471.9	473.7	475.5	477.3	479.1	480.9	482.7	484.5	486.3	488.1	489.9	491.7	493.5	495.3	497.1	498.9	500.7	502.5	504.3	506.1	507.9	509.7	511.5	513.3	515.1	516.9	518.7	520.5	522.3	524.1	525.9	527.7	529.5	531.3	533.1	534.9	536.7	538.5	540.3	542.1	543.9	545.7	547.5	549.3	551.1	552.9	554.7	556.5	558.3	560.1	561.9	563.7	565.5	567.3	569.1	570.9	572.7	574.5	576.3	578.1	579.9	581.7	583.5	585.3	587.1	588.9	590.7	592.5	594.3	596.1	597.9	599.7	601.5	603.3	605.1	606.9	608.7	610.5	612.3	614.1	615.9	617.7	619.5	621.3	623.1	624.9	626.7	628.5	630.3	632.1	633.9	635.7	637.5	639.3	641.1	642.9	644.7	646.5	648.3	650.1	651.9	653.7	655.5	657.3	659.1	660.9	662.7	664.5	666.3	668.1	669.9	671.7	673.5	675.3	677.1	678.9	680.7	682.5	684.3	686.1	687.9	689.7	691.5	693.3	695.1	696.9	698.7	700.5	702.3	704.1	705.9	707.7	709.5	711.3	713.1	714.9	716.7	718.5	720.3	722.1	723.9	725.7	727.5	729.3	731.1	732.9	734.7	736.5	738.3	740.1	741.9	743.7	745.5	747.3	749.1	750.9	752.7	754.5	756.3	758.1	759.9	761.7	763.5	765.3	767.1	768.9	770.7	772.5	774.3	776.1	777.9	779.7	781.5	783.3	785.1	786.9	788.7	790.5	792.3	794.1	795.9	797.7	799.5	801.3	803.1	804.9	806.7	808.5	810.3	812.1	813.9	815.7	817.5	819.3	821.1	822.9	824.7	826.5	828.3	830.1	831.9	833.7	835.5	837.3	839.1	840.9	842.7	844.5	846.3	848.1	849.9	851.7	853.5	855.3	857.1	858.9	860.7	862.5	864.3	866.1	867.9	869.7	871.5	873.3	875.1	876.9	878.7	880.5	882.3	884.1	885.9	887.7	889.5	891.3	893.1	894.9	896.7	898.5	900.3	902.1	903.9	905.7	907.5	909.3	911.1	912.9	914.7	916.5	918.3	920.1	921.9	923.7	925.5	927.3	929.1	930.9	932.7	934.5	936.3	938.1	939.9	941.7	943.5	945.3	947.1	948.9	950.7	952.5	954.3	956.1	957.9	959.7	961.5	963.3	965.1	966.9	968.7	970.5	972.3	974.1	975.9	977.7	979.5	981.3	983.1	984.9	986.7	988.5	990.3	992.1	993.9	995.7	997.5	999.3	1001.1	1002.9	1004.7	1006.5	1008.3	1010.1	1011.9	1013.7	1015.5	1017.3	1019.1	1020.9	1022.7	1024.5	1026.3	1028.1	1029.9	1031.7	1033.5	1035.3	1037.1	1038.9	1040.7	1042.5	1044.3	1046.1	1047.9	1049.7	1051.5	1053.3	1055.1	1056.9	1058.7	1060.5	1062.3	1064.1	1065.9	1067.7	1069.5	1071.3	1073.1	1074.9	1076.7	1078.5	1080.3	1082.1	1083.9	1085.7	1087.5	1089.3	1091.1	1092.9	1094.7	1096.5	1098.3	1100.1	1101.9	1103.7	1105.5	1107.3	1109.1	1110.9	1112.7	1114.5	1116.3	1118.1	1119.9	1121.7	1123.5	1125.3	1127.1	1128.9	1130.7	1132.5	1134.3	1136.1	1137.9	1139.7	1141.5	1143.3	1145.1	1146.9	1148.7	1150.5	1152.3	1154.1	1155.9	1157.7	1159.5	1161.3	1163.1	1164.9	1166.7	1168.5	1170.3	1172.1	1173.9	1175.7	1177.5	1179.3	1181.1	1182.9	1184.7	1186.5	1188.3	1190.1	1191.9	1193.7	1195.5	1197.3	1199.1	1200.9	1202.7	1204.5	1206.3	1208.1	1209.9	1211.7	1213.5	1215.3	1217.1	1218.9	1220.7	1222.5	1224.3	1226.1	1227.9	1229.7	1231.5	1233.3	1235.1	1236.9	1238.7	1240.5	1242.3	1244.1	1245.9	1247.7	1249.5	1251.3	1253.1	1254.9	1256.7	1258.5	1260.3	1262.1	1263.9	1265.7	1267.5	1269.3	1271.1	1272.9	1274.7	1276.5	1278.3	1280.1	1281.9	1283.7	1285.5	1287.3	1289.1	1290.9	1292.7	1294.5	1296.3	1298.1	1299.9	1301.7	1303.5	1305.3	1307.1	1308.9	1310.7	1312.5	1314.3	1316.1	1317.9	1319.7	1321.5	1323.3	1325.1	1326.9	1328.7	1330.5	1332.3	1334.1	1335.9	1337.7	1339.5	1341.3	1343.1	1344.9	1346.7	1348.5	1350.3	1352.1	1353.9	1355.7	1357.5	1359.3	1361.1	1362.9	1364.7	1366.5	1368.3	1370.1	1371.9	1373.7	1375.5	1377.3	1379.1	1380.9	1382.7	1384.5	1386.3	1388.1	1389.9	1391.7	1393.5	1395.3	1397.1	1398.9	1400.7	1402.5	1404.3	1406.1	1407.9	1409.7	1411.5	1413.3	1415.1	1416.9	1418.7	1420.5	1422.3	1424.1	1425.9	1427.7	1429.5	1431.3	1433.1	1434.9	1436.7	1438.5	1440.3	1442.1	1443.9	1445.7	1447.5	1449.3	1451.1	1452.9	1454.7	1456.5	1458.3	1460.1	1461.9	1463.7	1465.5	1467.3	1469.1	1470.9	1472.7	1474.5	1476.3	1478.1	1479.9	1481.7	1483.5	1485.3	1487.1	1488.9	1490.7	1492.5	1494.3	1496.1	1497.9	1499.7	1501.5	1503.3	1505.1	1506.9	1508.7	1510.5	1512.3	1514.1	1515.9	1517.7	1519.5	1521.3	1523.1	1524.9	1526.7	1528.5	1530.3	1532.1	1533.9	1535.7	1537.5	1539.3	1541.1	1542.9	1544.7	1546.5	1548.3	1550.1	1551.9	1553.7	1555.5	1557.3	1559.1	1560.9	1562.7	1564.5	1566.3	1568.1	1569.9	1571.7	1573.5	1575.3	1577.1	1578.9	1580.7	1582.5	1584.3	1586.1	1587.9	1589.7	1591.5	1593.3	1595.1	1596.9	1598.7	1600.5	1602.3	1604.1	1605.9	1607.7	1609.5	1611.3	1613.1	1614.9	1616.7	1618.5	1620.3	1622.1	1623.9	1625.7	1627.5	1629.3	1631.1	1632.9	1634.7	1636.5	1638.3	1640.1	1641.9	1643.7	1645.5	1647.3	1649.1	1650.9	1652.7	1654.5	1656.3	1658.1	1659.9	1661.7	1663.5	1665.3	1667.1	1668.9	1670.7	1672.5	1674.3	1676.1	1677.9	1679.7	1681.5	1683.3	1685.1	1686.9	1688.7	1690.5	1692.3	1694.1	1695.9	1697.7	1699.5	1701.3	1703.1	1704.9	1706.7	1708.5	1710.3	1712.1	1713.9	1715.7	1717.5	1719.3	1721.1	1722.9	1724.7	1726.5	1728.3	1730.1	1731.9	1733.7	1735.5	1737.3	1739.1	1740.9	1742.7	1744.5	1746.3	1748.1	1749.9	1751.7	1753.5	1755.3	1757.1	1758.9	1760.7	1762.5	1764.3	1766.1	1767.9	1769.7	1771.5	1773.3	1775.1	1776.9	1778.7	1780.5	1782.3	1784.1	1785.9	1787.7	1789.5	1791.3	1793.1	1794.9	1796.7	1798.5	1800.3	1802.1	1803.9	1805.7	1807.5	1809.3	1811.1	1812.9	1814.7	1816.5	1818.3	1820.1	1821.9	1823.7	1825.5	1827.3	1829.1	1830.9	1832.7	1834.5	1836.3	1838.1	1839.9	1841.7	1843.5	1845.3	1847.1	1848.9	1850.7	1852.5	1854.3	1856.1	1857.9	1859.7	1861.5	1863.3	1865.1	1866.9	1868.7	1870.5	1872.3	1874.1	1875.9	1877.7	1879.5	1881.3	1883.1	1884.9	1886.7	1888.5	1890.3	1892.1	1893.9	1895.7	1897.5	1899.3	1901.1	1902.9	1904.7	1906.5	1908.3	1910.1	1911.9	1913.7	1915.5	1917.3</

COOLING PERFORMANCE DATA

GPH1336H41**

EXPANDED PERFORMANCE DATA

MODEL: GPH1336H41**

COOLING OPERATION

Design Subcooling, 12±3 °F @ the liquid access fitting connection AHRI 95 test conditions. Design Superheat 8±3 °F @ the compressor suction access fitting connection.

IDB*	Airflow	Outdoor Ambient Temperature																								
		65				75				85				95				105				115				
		59	63	67	71	59	63	67	71	59	63	67	71	59	63	67	71	59	63	67	71	59	63	67	71	
70	1350	MBh	34.3	35.5	38.9	-	33.5	34.7	38.0	-	32.7	33.9	37.1	-	31.9	33.1	36.2	-	30.3	31.4	34.4	-	28.1	29.1	31.9	-
		S/T	0.76	0.63	0.44	-	0.79	0.66	0.45	-	0.81	0.67	0.47	-	0.83	0.69	0.48	-	0.86	0.72	0.50	-	0.87	0.73	0.50	-
		Delta T	18	15	12	-	18	16	12	-	18	16	12	-	18	16	12	-	18	15	12	-	17	14	11	-
		KW	2.61	2.66	2.74	-	2.80	2.85	2.94	-	2.96	3.02	3.12	-	3.11	3.18	3.27	-	3.23	3.30	3.41	-	3.34	3.41	3.52	-
		AMPS	11.1	11.3	11.6	-	11.8	12.1	12.4	-	12.7	13.0	13.3	-	13.4	13.7	14.1	-	14.2	14.5	14.9	-	14.9	15.2	15.7	-
	1200	HI PR	247	266	281	-	277	298	315	-	315	339	358	-	359	387	408	-	404	435	459	-	446	480	507	-
		LO PR	110	117	128	-	116	124	135	-	121	129	140	-	127	135	148	-	133	142	155	-	138	146	160	-
		MBh	33.3	34.5	37.8	-	32.5	33.7	36.9	-	31.7	32.9	36.1	-	31.0	32.1	35.2	-	29.4	30.5	33.4	-	27.3	28.3	31.0	-
		S/T	0.72	0.60	0.42	-	0.75	0.63	0.43	-	0.77	0.64	0.44	-	0.79	0.66	0.46	-	0.82	0.69	0.48	-	0.83	0.69	0.48	-
		Delta T	18	16	12	-	19	16	12	-	19	16	12	-	19	16	12	-	19	16	12	-	17	15	11	-
1050	KW	2.59	2.64	2.72	-	2.78	2.83	2.92	-	2.94	3.00	3.09	-	3.09	3.15	3.25	-	3.21	3.28	3.38	-	3.32	3.39	3.49	-	
	AMPS	11.0	11.2	11.5	-	11.8	12.0	12.3	-	12.6	12.9	13.2	-	13.3	13.6	14.0	-	14.1	14.4	14.8	-	14.8	15.1	15.6	-	
	HI PR	245	263	278	-	275	295	312	-	312	336	355	-	356	383	404	-	400	431	455	-	442	476	502	-	
	LO PR	109	116	127	-	115	123	134	-	120	127	139	-	126	134	146	-	132	140	153	-	136	145	158	-	
	MBh	30.7	31.9	34.9	-	30.0	31.1	34.1	-	29.3	30.4	33.3	-	28.6	29.6	32.5	-	27.2	28.2	30.8	-	25.2	26.1	28.6	-	
75	1350	S/T	0.70	0.58	0.40	-	0.72	0.60	0.42	-	0.74	0.62	0.43	-	0.76	0.64	0.44	-	0.79	0.66	0.46	-	0.80	0.67	0.46	-
		Delta T	19	16	12	-	19	16	12	-	19	16	12	-	19	17	13	-	19	16	12	-	18	15	12	-
		KW	2.53	2.58	2.66	-	2.71	2.77	2.85	-	2.87	2.93	3.02	-	3.01	3.08	3.17	-	3.13	3.20	3.30	-	3.24	3.30	3.41	-
		AMPS	10.8	11.0	11.3	-	11.5	11.7	12.0	-	12.3	12.6	12.9	-	13.0	13.3	13.7	-	13.7	14.0	14.4	-	14.4	14.8	15.2	-
		HI PR	237	255	270	-	266	287	303	-	303	326	344	-	345	371	392	-	388	418	441	-	429	461	487	-
	1200	LO PR	106	113	123	-	112	119	130	-	116	124	135	-	122	130	142	-	128	136	148	-	132	141	154	-
		MBh	34.9	35.9	38.9	41.7	34.1	35.1	38.0	40.7	33.3	34.2	37.1	39.8	32.4	33.4	36.2	38.8	30.8	31.7	34.4	36.9	28.6	29.4	31.8	34.2
		S/T	0.86	0.77	0.58	0.38	0.89	0.80	0.60	0.39	0.92	0.82	0.62	0.40	0.94	0.85	0.64	0.41	0.98	0.88	0.66	0.43	0.99	0.88	0.67	0.43
		Delta T	20	19	15	11	21	19	16	11	21	19	16	11	21	19	16	11	21	19	16	11	21	19	16	11
		KW	2.63	2.68	2.76	2.84	2.82	2.88	2.96	3.06	2.99	3.05	3.14	3.24	3.13	3.20	3.30	3.41	3.26	3.33	3.44	3.55	3.37	3.44	3.55	3.67
1050	AMPS	11.2	11.4	11.7	12.1	11.9	12.2	12.5	12.9	12.8	13.1	13.4	13.9	13.6	13.8	14.2	14.7	14.3	14.6	15.0	15.5	15.0	15.4	15.8	16.4	
	HI PR	250	269	284	296	280	301	318	332	319	343	362	378	363	391	412	430	408	439	464	484	451	485	513	535	
	LO PR	111	118	129	138	118	125	137	145	122	130	142	151	128	137	149	159	134	143	156	166	139	148	162	172	
	MBh	33.9	34.9	37.7	40.5	33.1	34.1	36.9	39.6	32.3	33.2	36.0	38.6	31.5	32.4	35.1	37.7	29.9	30.8	33.3	35.8	27.7	28.5	30.9	33.2	
	S/T	0.82	0.73	0.56	0.36	0.85	0.76	0.58	0.37	0.87	0.78	0.59	0.38	0.90	0.81	0.61	0.39	0.94	0.84	0.63	0.41	0.94	0.84	0.64	0.41	
70	1350	Delta T	21	20	16	11	22	20	16	11	22	20	16	11	22	20	16	11	21	20	16	11	20	18	15	10
		KW	2.61	2.66	2.74	2.82	2.80	2.85	2.94	3.03	2.96	3.02	3.12	3.22	3.11	3.18	3.27	3.38	3.23	3.30	3.41	3.52	3.34	3.41	3.52	3.64
		AMPS	11.1	11.3	11.6	12.0	11.8	12.1	12.4	12.8	12.7	13.0	13.3	13.8	13.4	13.7	14.1	14.6	14.2	14.5	14.9	15.4	14.9	15.2	15.7	16.2
		HI PR	247	266	281	293	277	298	315	329	315	339	358	374	359	387	408	426	404	435	459	479	447	481	507	529
		LO PR	110	117	128	136	116	124	135	144	121	129	140	150	127	135	148	157	133	142	155	165	138	147	160	170
	1200	MBh	31.3	32.2	34.8	37.4	30.5	31.4	34.0	36.5	29.8	30.7	33.2	35.6	29.1	29.9	32.4	34.8	27.6	28.4	30.8	33.0	25.6	26.3	28.5	30.6
		S/T	0.79	0.71	0.54	0.34	0.82	0.73	0.56	0.36	0.84	0.75	0.57	0.37	0.87	0.78	0.59	0.38	0.90	0.81	0.61	0.39	0.91	0.81	0.62	0.40
		Delta T	22	20	16	11	22	20	17	11	22	20	17	11	22	20	17	11	22	20	16	11	20	19	15	11
		KW	2.55	2.60	2.68	2.76	2.73	2.79	2.87	2.96	2.89	2.95	3.04	3.14	3.04	3.10	3.20	3.30	3.16	3.22	3.33	3.43	3.26	3.33	3.44	3.55
		AMPS	10.9	11.1	11.4	11.7	11.6	11.8	12.1	12.5	12.4	12.7	13.0	13.4	13.1	13.4	13.8	14.2	13.9	14.1	14.6	15.0	14.6	14.9	15.3	15.8
1050	HI PR	240	258	272	284	269	290	306	319	306	329	346	363	349	375	396	413	392	422	446	465	433	466	492	513	
	LO PR	107	114	124	132	113	120	131	140	117	125	136	145	123	131	143	152	129	137	150	160	134	142	155	165	

* Entering Indoor Dry Bulb Temperature

NOTE: Shaded area is ACCA (TVA) conditions. High and low pressures are measured at the liquid and suction access fittings.

COOLING PERFORMANCE DATA

GPH1336H41**

EXPANDED PERFORMANCE DATA

EXPANDED PERFORMANCE DATA

MODEL: GPH1336H41**

Design Subcooling, 12±3 °F @ the liquid access fitting connection AHRI 95 test conditions. Design Superheat 8±3 °F @ the compressor suction access fitting connection.

IDB*	Airflow	Outdoor Ambient Temperature																								
		65				75				85				95				105				115				
		59	63	67	71	59	63	67	71	59	63	67	71	59	63	67	71	59	63	67	71	59	63	67	71	
80	1350	MBh	35.5	36.3	38.8	41.4	34.7	35.4	37.9	40.5	33.8	34.6	37.0	39.5	33.0	33.7	36.1	38.5	31.4	32.1	34.2	36.6	29.1	29.7	31.7	33.9
		S/T	0.94	0.89	0.72	0.54	1.00	0.92	0.75	0.56	1.00	0.94	0.77	0.57	1.00	1.00	0.79	0.59	1.00	1.00	0.82	0.61	1.00	1.00	0.83	0.62
		Delta T	23	22	19	15	24	22	19	15	23	22	19	15	22	23	19	16	21	22	19	15	20	20	18	14
		KW	2.65	2.70	2.78	2.87	2.84	2.90	2.99	3.08	3.01	3.07	3.17	3.27	3.16	3.23	3.33	3.43	3.29	3.36	3.46	3.57	3.40	3.47	3.58	3.70
		AMPS	11.3	11.5	11.8	12.2	12.0	12.3	12.6	13.0	12.9	13.2	13.5	14.0	13.7	14.0	14.4	14.8	14.4	14.7	15.2	15.7	15.2	15.5	16.0	16.5
		HI PR	252	271	287	299	283	305	322	335	322	346	366	381	367	394	417	434	412	444	469	489	456	490	518	540
		LO PR	112	120	131	139	119	126	138	147	123	131	143	153	130	138	151	160	136	145	158	168	141	149	163	174
		MBh	34.5	35.2	37.6	40.2	33.7	34.4	36.8	39.3	32.9	33.6	35.9	38.4	32.1	32.8	35.0	37.4	30.5	31.1	33.3	35.5	28.2	28.8	30.8	32.9
		S/T	0.90	0.84	0.69	0.51	0.93	0.88	0.71	0.53	0.96	0.90	0.73	0.55	0.99	0.93	0.75	0.56	1.00	0.96	0.78	0.59	1.00	0.97	0.79	0.59
		Delta T	24	23	20	16	24	23	20	16	24	23	20	16	24	24	20	16	24	23	20	16	22	21	19	15
1050	1200	MBh	2.63	2.68	2.76	2.84	2.82	2.88	2.96	3.06	2.99	3.05	3.14	3.24	3.13	3.20	3.30	3.41	3.26	3.33	3.44	3.55	3.37	3.44	3.55	3.67
		S/T	11.2	11.4	11.7	12.1	11.9	12.2	12.5	12.9	12.8	13.1	13.4	13.9	13.6	13.8	14.2	14.7	14.3	14.6	15.0	15.5	15.0	15.4	15.8	16.4
		HI PR	250	269	284	296	280	301	318	332	319	343	362	378	363	391	412	430	408	439	464	484	451	485	513	535
		LO PR	111	118	129	138	118	125	137	145	122	130	142	151	128	137	149	159	134	143	156	166	139	148	162	172
		MBh	31.8	32.5	34.7	37.1	31.1	31.7	33.9	36.3	30.3	31.0	33.1	35.4	29.6	30.2	32.3	34.5	28.1	28.7	30.7	32.8	26.0	26.6	28.4	30.4
		S/T	0.87	0.81	0.66	0.50	0.90	0.84	0.69	0.51	0.92	0.87	0.70	0.53	0.95	0.89	0.73	0.54	0.99	0.93	0.75	0.56	1.00	0.94	0.76	0.57
		Delta T	24	23	20	16	24	23	20	16	25	23	20	16	25	24	21	16	24	23	20	16	23	22	19	15
		KW	2.57	2.62	2.70	2.78	2.75	2.81	2.89	2.98	2.92	2.98	3.07	3.16	3.06	3.12	3.22	3.32	3.18	3.25	3.35	3.46	3.29	3.36	3.46	3.58
		AMPS	10.9	11.2	11.5	11.8	11.7	11.9	12.2	12.6	12.5	12.8	13.1	13.5	13.2	13.5	13.9	14.4	14.0	14.3	14.7	15.2	14.7	15.0	15.4	16.0
		HI PR	242	261	275	287	272	292	309	322	309	333	351	366	352	379	400	417	396	426	450	469	438	471	497	519
LO PR	108	115	125	133	114	121	132	141	119	126	138	147	124	132	145	154	130	139	152	161	135	144	157	167		

1350	MBh	36.1	36.8	38.6	41.1	35.3	36.0	37.7	40.2	34.4	35.1	36.8	39.2	33.6	34.2	35.9	38.3	31.9	32.5	34.1	36.4	29.6	30.1	31.6	33.7
	S/T	0.99	0.96	0.86	0.70	1.00	0.99	0.89	0.73	1.00	1.00	0.92	0.74	1.00	1.00	0.95	0.77	1.00	1.00	0.98	0.80	1.00	1.00	0.99	0.80
	Delta T	24	24	23	20	24	24	23	20	23	24	23	20	23	23	23	20	22	22	23	20	20	21	21	18
	KW	2.67	2.72	2.80	2.89	2.86	2.92	3.01	3.10	3.03	3.10	3.19	3.29	3.18	3.25	3.35	3.46	3.31	3.38	3.49	3.60	3.42	3.50	3.61	3.73
	AMPS	11.4	11.6	11.9	12.3	12.1	12.4	12.7	13.1	13.0	13.3	13.7	14.1	13.8	14.1	14.5	14.9	14.5	14.8	15.3	15.8	15.3	15.6	16.1	16.6
	HI PR	255	274	289	302	286	308	325	339	325	350	369	385	370	398	421	439	416	448	473	494	460	495	523	545
	LO PR	114	121	132	140	120	128	139	148	125	133	145	154	131	139	152	162	137	146	159	170	142	151	165	176
	MBh	35.1	35.7	37.4	39.9	34.3	34.9	36.6	39.0	33.4	34.1	35.7	38.1	32.6	33.3	34.8	37.2	31.0	31.6	33.1	35.3	28.7	29.3	30.6	32.7
	S/T	0.94	0.91	0.82	0.67	0.98	0.94	0.85	0.69	1.00	0.97	0.87	0.71	1.00	1.00	0.90	0.73	1.00	1.00	0.94	0.76	1.00	1.00	0.94	0.77
	Delta T	25	25	24	20	26	25	24	21	26	25	24	21	25	25	24	21	24	24	24	21	22	22	22	19
1200	KW	2.65	2.70	2.78	2.87	2.84	2.90	2.99	3.08	3.01	3.07	3.17	3.27	3.16	3.23	3.33	3.43	3.29	3.36	3.46	3.57	3.40	3.47	3.58	3.70
	AMPS	11.3	11.5	11.8	12.2	12.0	12.3	12.6	13.0	12.9	13.2	13.5	14.0	13.7	14.0	14.4	14.8	14.4	14.7	15.2	15.7	15.2	15.5	16.0	16.5
	HI PR	252	271	287	299	283	305	322	335	322	346	366	381	367	394	417	434	412	444	469	489	456	490	518	540
	LO PR	112	120	131	139	119	126	138	147	123	131	143	153	130	138	151	160	136	145	158	168	141	149	163	174
	MBh	32.4	33.0	34.6	36.9	31.6	32.2	33.8	36.0	30.9	31.5	32.9	35.1	30.1	30.7	32.1	34.3	28.6	29.2	30.5	32.6	26.5	27.0	28.3	30.2
	S/T	0.91	0.88	0.79	0.64	0.94	0.91	0.82	0.67	0.97	0.93	0.84	0.68	1.00	0.96	0.87	0.71	1.00	1.00	0.90	0.73	1.00	1.00	0.91	0.74
	Delta T	26	25	24	21	26	26	24	21	26	26	24	21	26	26	24	21	25	26	24	21	23	24	23	20
	KW	2.59	2.64	2.72	2.80	2.78	2.83	2.92	3.01	2.94	3.00	3.09	3.19	3.08	3.15	3.25	3.35	3.21	3.28	3.38	3.49	3.31	3.39	3.49	3.61
	AMPS	11.0	11.2	11.5	11.9	11.8	12.0	12.3	12.7	12.6	12.9	13.2	13.7	13.3	13.6	14.0	14.5	14.1	14.4	14.8	15.3	14.8	15.1	15.6	16.1
	HI PR	245	263	278	290	274	295	312	325	312	336	355	370	356	383	404	421	400	430	455	474	442	476	502	524
LO PR	109	116	127	135	115	123	134	142	120	127	139	148	126	134	146	156	132	140	153	163	136	145	158	169	

* Entering Indoor Dry Bulb Temperature
 High and low pressures are measured at the liquid and suction access fittings.
 NOTE: Shaded area is AHR1 Rating Conditions
 KW = Total system power
 AMPS: Unit amps (comp. + evaporator + condenser fan motors)

COOLING PERFORMANCE DATA

GPH1342H41**

MODEL: GPH1342H41**

EXPANDED PERFORMANCE DATA

COOLING OPERATION

Design Subcooling, 12±3 °F @ the liquid access fitting connection ARI 95 test conditions. Design Superheat 8±3 °F @ the compressor suction access fitting connection.

IDB*	Airflow	Outdoor Ambient Temperature																								
		65			75			85			95			105			115									
		59	63	67	71	59	63	67	71	59	63	67	71	59	63	67	71	59	63	67	71					
70	1585	MBh	39.7	41.1	45.1	-	38.8	40.2	44.0	-	37.8	39.2	43.0	-	36.9	38.3	41.9	-	35.1	36.4	39.8	-	32.5	33.7	36.9	-
		S/T	0.76	0.63	0.44	-	0.79	0.66	0.46	-	0.81	0.67	0.47	-	0.83	0.70	0.48	-	0.87	0.72	0.50	-	0.87	0.73	0.50	-
		Delta T	17	15	11	-	18	15	12	-	18	15	12	-	18	15	12	-	18	15	12	-	16	14	11	-
		KW	2.82	2.88	2.96	-	3.02	3.08	3.17	-	3.20	3.26	3.36	-	3.35	3.42	3.52	-	3.48	3.55	3.66	-	3.59	3.67	3.78	-
		AMPS	12.4	12.6	13.0	-	13.2	13.5	13.8	-	14.2	14.4	14.8	-	15.0	15.3	15.7	-	15.8	16.1	16.6	-	16.6	16.9	17.4	-
	1410	HI PR	235	253	267	-	264	284	300	-	300	323	341	-	342	368	388	-	384	414	437	-	425	457	483	-
		LO PR	113	120	132	-	120	127	139	-	124	132	144	-	131	139	152	-	137	146	159	-	142	151	164	-
		MBh	38.5	39.9	43.8	-	37.6	39.0	42.7	-	36.7	38.1	41.7	-	35.8	37.1	40.7	-	34.1	35.3	38.7	-	31.5	32.7	35.8	-
		S/T	0.72	0.61	0.42	-	0.75	0.63	0.43	-	0.77	0.64	0.45	-	0.79	0.66	0.46	-	0.83	0.69	0.48	-	0.83	0.69	0.48	-
		Delta T	18	16	12	-	18	16	12	-	18	16	12	-	19	16	12	-	18	16	12	-	17	15	11	-
1236	KW	2.80	2.86	2.94	-	3.00	3.06	3.15	-	3.17	3.24	3.33	-	3.32	3.39	3.49	-	3.45	3.52	3.63	-	3.57	3.64	3.75	-	
	AMPS	12.3	12.5	12.9	-	13.1	13.4	13.7	-	14.0	14.3	14.7	-	14.9	15.2	15.6	-	15.7	16.0	16.4	-	16.5	16.8	17.3	-	
	HI PR	233	251	265	-	261	281	297	-	297	320	338	-	338	364	385	-	381	410	433	-	421	453	478	-	
	LO PR	112	119	130	-	118	126	138	-	123	131	143	-	129	138	150	-	136	144	157	-	140	149	163	-	
	MBh	35.6	36.9	40.4	-	34.7	36.0	39.4	-	33.9	35.1	38.5	-	33.1	34.3	37.6	-	31.4	32.6	35.7	-	29.1	30.2	33.1	-	
75	1585	S/T	0.70	0.58	0.40	-	0.72	0.60	0.42	-	0.74	0.62	0.43	-	0.77	0.64	0.44	-	0.80	0.66	0.46	-	0.80	0.67	0.46	-
		Delta T	18	16	12	-	19	16	12	-	19	16	12	-	19	16	12	-	19	16	12	-	17	15	11	-
		KW	2.74	2.80	2.88	-	2.93	2.99	3.08	-	3.10	3.16	3.26	-	3.25	3.31	3.41	-	3.37	3.44	3.55	-	3.48	3.55	3.66	-
		AMPS	12.0	12.3	12.6	-	12.8	13.1	13.4	-	13.7	14.0	14.4	-	14.5	14.8	15.2	-	15.3	15.6	16.1	-	16.1	16.4	16.9	-
		HI PR	226	243	257	-	253	273	288	-	288	310	327	-	328	353	373	-	369	397	420	-	408	439	464	-
	1410	LO PR	109	116	126	-	115	122	133	-	119	127	139	-	125	133	146	-	131	140	153	-	136	145	158	-
		MBh	40.4	41.6	45.0	48.3	39.4	40.6	43.9	47.2	38.5	39.6	42.9	46.0	37.5	38.7	41.8	44.9	35.7	36.7	39.7	42.7	33.0	34.0	36.8	39.5
		S/T	0.86	0.77	0.58	0.38	0.90	0.80	0.61	0.39	0.92	0.82	0.62	0.40	0.95	0.85	0.64	0.41	0.98	0.88	0.67	0.43	0.99	0.89	0.67	0.43
		Delta T	20	19	15	11	20	19	15	11	20	19	15	11	21	19	16	11	20	19	15	11	20	18	14	10
		KW	2.85	2.90	2.98	3.07	3.04	3.10	3.20	3.29	3.22	3.29	3.38	3.49	3.38	3.44	3.55	3.66	3.51	3.58	3.69	3.81	3.62	3.70	3.81	3.93
1236	AMPS	12.5	12.7	13.1	13.5	13.3	13.6	13.9	14.4	14.3	14.6	15.0	15.4	15.1	15.4	15.8	16.4	15.9	16.2	16.7	17.3	16.7	17.1	17.6	18.2	
	HI PR	238	256	270	282	267	287	303	316	303	326	344	359	345	372	392	409	388	418	441	460	429	462	488	509	
	LO PR	114	122	133	141	121	129	140	149	126	134	146	155	132	140	153	163	138	147	161	171	143	152	166	177	
	MBh	39.2	40.3	43.7	46.9	38.3	39.4	42.7	45.8	37.4	38.5	41.6	44.7	36.5	37.5	40.6	43.6	34.6	35.7	38.6	41.4	32.1	33.0	35.7	38.4	
	S/T	0.82	0.74	0.56	0.36	0.85	0.76	0.58	0.37	0.88	0.78	0.59	0.38	0.90	0.81	0.61	0.39	0.94	0.84	0.63	0.41	0.95	0.85	0.64	0.41	
75	1585	Delta T	21	19	16	11	21	20	16	11	21	20	16	11	21	20	16	11	21	20	16	11	20	18	15	10
		KW	2.82	2.88	2.96	3.05	3.02	3.08	3.17	3.27	3.20	3.26	3.36	3.46	3.35	3.42	3.52	3.63	3.48	3.55	3.66	3.78	3.59	3.67	3.78	3.90
		AMPS	12.4	12.6	13.0	13.4	13.2	13.5	13.8	14.3	14.2	14.4	14.8	15.3	15.0	15.3	15.7	16.2	15.8	16.1	16.6	17.1	16.6	16.9	17.4	18.0
		HI PR	235	253	267	279	264	284	300	313	300	323	341	356	342	368	388	405	385	414	437	456	425	457	483	504
		LO PR	113	120	132	140	120	127	139	148	124	132	144	154	131	139	152	162	137	146	159	169	142	151	164	175
	1410	MBh	36.2	37.2	40.3	43.3	35.3	36.4	39.4	42.3	34.5	35.5	38.4	41.2	33.6	34.6	37.5	40.2	32.0	32.9	35.6	38.2	29.6	30.5	33.0	35.4
		S/T	0.79	0.71	0.54	0.35	0.82	0.74	0.56	0.36	0.84	0.75	0.57	0.37	0.87	0.78	0.59	0.38	0.90	0.81	0.61	0.39	0.91	0.82	0.62	0.40
		Delta T	21	20	16	11	22	20	16	11	22	20	16	11	22	20	16	11	22	20	16	11	20	18	15	10
		KW	2.76	2.82	2.90	2.98	2.96	3.01	3.10	3.19	3.12	3.19	3.28	3.38	3.27	3.34	3.44	3.55	3.40	3.47	3.58	3.69	3.51	3.58	3.69	3.81
		AMPS	12.1	12.4	12.7	13.1	12.9	13.2	13.5	13.9	13.8	14.1	14.5	15.0	14.6	14.9	15.3	15.8	15.4	15.7	16.2	16.7	16.2	16.5	17.0	17.6
1236	HI PR	228	245	259	270	256	275	291	303	291	313	331	345	332	357	377	393	373	401	424	442	412	444	468	488	
	LO PR	110	117	128	136	116	123	135	144	121	128	140	149	127	135	147	157	133	141	154	164	137	146	160	170	

* IDB: Entering Indoor Dry Bulb Temperature

NOTE: Shaded area is ACCA (TVA) conditions

High and low pressures are measured at the liquid and suction access fittings.

Design Subcooling, 12±3 °F @ the liquid access fitting connection AHRI 95 test conditions. Design Superheat 8±3 °F @ the compressor suction access fitting connection.

IDB*	Airflow	Outdoor Ambient Temperature																									
		65				75				85				95				105				115					
		59	63	67	71	59	63	67	71	59	63	67	71	59	63	67	71	59	63	67	71	59	63	67	71		
80	1685	MBh	41.1	42.0	44.8	47.9	40.1	41.0	43.8	46.8	39.2	40.0	42.8	45.7	38.2	39.0	41.7	44.6	36.3	37.1	39.6	42.4	33.6	34.4	36.7	39.2	
		S/T	0.95	0.89	0.72	0.54	1.00	0.92	0.75	0.56	1.00	0.94	0.77	0.57	1.00	1.00	0.79	0.59	1.00	1.00	0.82	0.62	1.00	1.00	0.83	0.62	
		Delta T	23	22	19	15	23	22	19	15	23	22	19	15	22	23	19	15	21	21	22	19	15	20	20	18	14
		KW	2.87	2.92	3.01	3.09	3.07	3.13	3.22	3.32	3.24	3.31	3.41	3.52	3.40	3.47	3.58	3.69	3.54	3.54	3.61	3.72	3.84	3.65	3.73	3.84	3.96
		AMPS	12.6	12.8	13.2	13.6	13.4	13.7	14.1	14.5	14.4	14.7	15.1	15.6	15.2	15.5	16.0	16.5	16.0	16.4	16.8	17.4	18.3	16.9	17.2	17.7	18.3
		H1PR	240	258	273	284	269	290	306	319	306	329	348	363	349	375	396	413	392	422	446	465	433	466	493	514	
		LO PR	116	123	134	143	122	130	142	151	127	135	147	157	133	142	155	165	140	149	162	173	144	154	168	179	
		MBh	39.9	40.8	43.5	46.5	39.0	39.8	42.5	45.5	38.0	38.9	41.5	44.4	37.1	37.9	40.5	43.3	35.2	36.0	38.5	41.1	32.6	33.4	35.6	38.1	
		S/T	0.90	0.85	0.69	0.52	0.94	0.88	0.71	0.53	0.96	0.90	0.73	0.55	0.99	0.93	0.76	0.57	1.00	0.96	0.79	0.59	1.00	0.97	0.79	0.59	
		Delta T	23	23	20	16	24	23	20	16	24	23	20	16	24	24	23	20	16	24	23	20	16	21	21	18	15
KW	2.85	2.90	2.98	3.07	3.04	3.10	3.20	3.29	3.22	3.29	3.38	3.49	3.38	3.45	3.55	3.66	3.51	3.58	3.69	3.81	3.62	3.70	3.81	3.93			
AMPS	12.5	12.7	13.1	13.5	13.3	13.6	14.0	14.4	14.3	14.6	15.0	15.4	15.1	15.4	15.8	16.4	15.9	16.2	16.7	17.3	16.7	17.1	17.6	18.2			
H1PR	238	256	270	282	267	287	303	316	303	326	344	359	345	372	392	409	388	418	441	460	429	462	488	509			
LO PR	114	122	133	142	121	129	140	150	126	134	146	155	132	140	153	163	138	147	161	171	143	152	166	177			
MBh	36.8	37.6	40.2	43.0	36.0	36.7	39.3	42.0	35.1	35.9	38.3	41.0	34.2	35.0	37.4	40.0	32.5	33.2	35.5	38.0	30.1	30.8	32.9	35.2			
S/T	0.87	0.82	0.66	0.50	0.90	0.85	0.69	0.52	0.93	0.87	0.71	0.53	0.96	0.90	0.73	0.55	0.99	0.93	0.76	0.57	1.00	0.94	0.76	0.57			
Delta T	24	23	20	16	24	23	20	16	24	23	20	16	24	24	23	20	16	24	23	20	16	22	21	19	15		
KW	2.78	2.84	2.92	3.00	2.98	3.04	3.12	3.22	3.15	3.21	3.31	3.41	3.30	3.37	3.47	3.57	3.43	3.50	3.60	3.72	3.54	3.61	3.72	3.84			
AMPS	12.2	12.5	12.8	13.2	13.0	13.3	13.6	14.1	13.9	14.2	14.6	15.1	14.7	15.0	15.5	16.0	15.5	15.9	16.3	16.8	16.3	16.7	17.2	17.7			
H1PR	230	248	262	273	259	278	294	306	294	316	334	349	335	360	381	397	377	405	428	447	416	448	473	493			
LO PR	111	118	129	137	117	125	136	145	122	130	142	151	128	136	149	158	134	143	156	166	139	148	161	172			

85	1585	MBh	41.8	42.6	44.6	47.6	40.8	41.6	43.6	46.5	39.9	40.6	42.5	45.4	38.9	39.6	41.5	44.3	36.9	37.6	39.4	42.1	34.2	34.9	36.5	39.0	
		S/T	0.99	0.96	0.86	0.70	1.00	0.99	0.90	0.73	1.00	1.00	0.92	0.75	1.00	1.00	0.95	0.77	1.00	1.00	0.98	0.80	1.00	1.00	0.99	0.81	
		Delta T	24	24	22	19	24	24	23	20	23	24	23	20	23	23	23	20	23	21	22	23	19	20	20	21	18
		KW	2.89	2.94	3.03	3.12	3.09	3.15	3.24	3.34	3.27	3.34	3.44	3.54	3.43	3.50	3.61	3.72	3.56	3.64	3.75	3.87	3.68	3.76	3.87	4.00	
		AMPS	12.7	12.9	13.3	13.7	13.5	13.8	14.2	14.6	14.5	14.8	15.2	15.7	15.3	15.6	16.1	16.6	16.2	16.5	17.0	17.5	17.0	17.4	17.9	18.5	
		H1PR	242	261	275	287	272	293	309	322	309	333	351	367	352	379	400	417	396	426	450	470	438	471	497	519	
		LO PR	117	124	136	144	123	131	143	153	128	136	149	159	135	143	156	166	141	150	164	174	146	155	169	180	
		MBh	40.6	41.4	43.3	46.2	39.6	40.4	42.3	45.1	38.7	39.4	41.3	44.1	37.7	38.5	40.3	43.0	35.9	36.6	38.3	40.8	33.2	33.9	35.5	37.8	
		S/T	0.95	0.91	0.82	0.67	0.98	0.95	0.85	0.69	1.00	0.97	0.88	0.71	1.00	1.00	0.90	0.73	1.00	1.00	0.94	0.76	1.00	1.00	0.95	0.77	
		Delta T	25	25	23	20	25	25	24	20	25	25	24	20	25	25	24	21	23	24	23	20	22	22	22	19	
KW	2.87	2.92	3.01	3.09	3.07	3.13	3.22	3.32	3.24	3.31	3.41	3.52	3.40	3.47	3.58	3.69	3.54	3.61	3.72	3.84	3.65	3.73	3.84	3.96			
AMPS	12.6	12.8	13.2	13.6	13.4	13.7	14.1	14.5	14.4	14.7	15.1	15.6	15.2	15.5	16.0	16.5	16.0	16.4	16.8	17.4	16.9	17.2	17.7	18.3			
H1PR	240	258	273	284	269	290	306	319	306	329	348	363	349	375	396	413	392	422	446	465	433	466	493	514			
LO PR	116	123	134	143	122	130	142	151	127	135	147	157	133	142	155	165	140	149	162	173	144	154	168	179			
MBh	37.5	38.2	40.0	42.7	36.6	37.3	39.1	41.7	35.7	36.4	38.1	40.7	34.8	35.5	37.2	39.7	33.1	33.7	35.3	37.7	30.7	31.3	32.7	34.9			
S/T	0.91	0.88	0.80	0.65	0.95	0.91	0.82	0.67	0.97	0.94	0.85	0.69	1.00	0.97	0.87	0.71	1.00	1.00	0.91	0.73	1.00	1.00	0.91	0.74			
Delta T	25	25	24	20	26	25	24	21	26	25	24	21	26	26	24	21	25	25	24	21	23	23	23	22	19		
KW	2.80	2.86	2.94	3.03	3.00	3.06	3.15	3.24	3.17	3.23	3.33	3.43	3.32	3.39	3.49	3.60	3.45	3.52	3.63	3.75	3.56	3.64	3.75	3.87			
AMPS	12.3	12.5	12.9	13.3	13.1	13.4	13.7	14.2	14.0	14.3	14.7	15.2	14.9	15.2	15.6	16.1	15.7	16.0	16.4	17.0	16.5	16.8	17.3	17.9			
H1PR	233	250	264	276	261	281	297	310	297	320	337	352	338	364	384	401	381	410	432	451	420	452	478	498			
LO PR	112	119	130	139	118	126	138	146	123	131	143	152	129	138	150	160	135	144	157	168	140	149	163	173			

* Entering Indoor Dry Bulb Temperature
 High and low pressures are measured at the liquid and suction access fittings.
 NOTE: Shaded area is AHRI Rating Conditions
 KW = Total system power
 AMPS: Unit amps (comp. + evaporator + condenser fan motors)

COOLING PERFORMANCE DATA

GPH1348H41**

MODEL: GPH1348H41**

EXPANDED PERFORMANCE DATA

COOLING OPERATION

Design Subcooling, 12±3 °F @ the liquid access fitting connection AHRI 95 test conditions. Design Superheat 8±3 °F @ the compressor suction access fitting connection.

IDB*	Airflow	Outdoor Ambient Temperature																									
		65				75				85				95				105				115					
		59	63	67	71	59	63	67	71	59	63	67	71	59	63	67	71	59	63	67	71	59	63	67	71		
70	1800	MBh	45.1	46.7	51.2	-	44.0	45.6	50.0	-	43.0	44.5	48.8	-	41.9	43.5	47.6	-	39.8	41.3	45.2	-	36.9	38.2	41.9	-	
		S/T	0.78	0.65	0.45	-	0.81	0.67	0.47	-	0.83	0.69	0.48	-	0.85	0.71	0.49	-	0.89	0.74	0.51	-	0.89	0.75	0.52	-	
		Delta T	18	16	12	-	18	16	12	-	18	16	12	-	18	16	12	-	18	16	12	-	17	15	11	-	
		KW	3.09	3.15	3.24	-	3.31	3.37	3.47	-	3.50	3.57	3.67	-	3.66	3.74	3.85	-	3.81	3.88	4.00	-	3.93	4.01	4.13	-	
		AMPS	13.6	13.8	14.2	-	14.5	14.7	15.1	-	15.5	15.8	16.2	-	16.4	16.7	17.2	-	17.2	17.6	18.1	-	18.1	18.5	19.0	-	
		HI PR	228	245	259	-	256	275	290	-	291	313	330	-	331	356	376	-	372	401	423	-	411	443	468	-	
		LO PR	109	116	127	-	116	123	134	-	120	128	139	-	126	134	146	-	132	141	154	-	137	145	159	-	
		MBh	43.8	45.4	49.7	-	42.7	44.3	48.5	-	41.7	43.2	47.4	-	40.7	42.2	46.2	-	38.7	40.1	43.9	-	35.8	37.1	40.7	-	
		S/T	0.74	0.62	0.43	-	0.77	0.64	0.45	-	0.79	0.66	0.46	-	0.81	0.68	0.47	-	0.85	0.71	0.49	-	0.85	0.71	0.49	-	
		Delta T	19	16	12	-	19	16	12	-	19	16	12	-	19	16	13	-	19	16	12	-	18	15	12	-	
70	1600	MBh	3.07	3.13	3.22	-	3.28	3.35	3.44	-	3.47	3.54	3.64	-	3.64	3.71	3.82	-	3.78	3.85	3.97	-	3.90	3.98	4.10	-	
		AMPS	13.5	13.7	14.1	-	14.4	14.6	15.0	-	15.4	15.7	16.1	-	16.2	16.6	17.0	-	17.1	17.5	18.0	-	18.0	18.3	18.9	-	
		HI PR	225	243	256	-	253	272	287	-	288	310	327	-	328	353	372	-	369	397	419	-	407	438	463	-	
		LO PR	108	115	126	-	114	122	133	-	119	126	138	-	125	133	145	-	131	139	152	-	135	144	157	-	
		MBh	40.4	41.9	45.9	-	39.5	40.9	44.8	-	38.5	39.9	43.7	-	37.6	38.9	42.7	-	35.7	37.0	40.5	-	33.1	34.3	37.5	-	
		S/T	0.72	0.60	0.41	-	0.74	0.62	0.43	-	0.76	0.64	0.44	-	0.79	0.66	0.45	-	0.82	0.68	0.47	-	0.82	0.69	0.48	-	
		Delta T	19	16	12	-	19	17	13	-	19	17	13	-	19	17	13	-	19	17	13	-	18	15	12	-	
		KW	3.01	3.06	3.15	-	3.21	3.27	3.37	-	3.39	3.46	3.56	-	3.55	3.62	3.73	-	3.69	3.76	3.88	-	3.81	3.89	4.00	-	
		AMPS	13.2	13.4	13.8	-	14.0	14.3	14.7	-	15.0	15.3	15.7	-	15.9	16.2	16.6	-	16.7	17.1	17.5	-	17.5	17.9	18.4	-	
		HI PR	219	235	249	-	245	264	279	-	279	300	317	-	318	342	361	-	358	385	406	-	395	425	449	-	
LO PR	105	112	122	-	111	118	129	-	115	123	134	-	121	129	141	-	127	135	147	-	131	140	153	-			
75	1800	MBh	45.8	47.2	51.1	54.8	44.8	46.1	49.9	53.6	43.7	45.0	48.7	52.3	42.6	43.9	47.5	51.0	40.5	41.7	45.1	48.5	37.5	38.6	41.8	44.9	
		S/T	0.88	0.79	0.60	0.39	0.92	0.82	0.62	0.40	0.41	0.94	0.84	0.64	0.41	0.97	0.87	0.66	0.42	1.00	0.90	0.68	0.44	1.00	0.91	0.69	0.44
		Delta T	21	19	16	11	21	19	16	11	11	21	19	16	11	21	19	16	11	21	19	16	11	19	18	15	10
		KW	3.12	3.18	3.27	3.36	3.33	3.40	3.50	3.60	3.62	3.52	3.59	3.70	3.81	3.69	3.77	3.88	4.00	3.84	3.91	4.03	4.16	3.96	4.04	4.17	4.30
		AMPS	13.7	13.9	14.3	14.7	14.6	14.9	15.3	15.7	15.7	15.6	15.9	16.4	16.9	16.5	16.8	17.3	17.9	17.4	17.7	18.2	18.8	18.3	18.6	19.2	19.8
		HI PR	230	248	261	273	258	278	293	306	306	294	316	334	348	334	360	380	396	376	405	427	446	416	447	472	493
		LO PR	110	118	128	137	117	124	136	144	144	121	129	141	150	127	136	148	158	134	142	155	165	138	147	160	171
		MBh	44.5	45.8	49.6	53.2	43.5	44.8	48.4	52.0	52.0	42.4	43.7	47.3	50.8	41.4	42.6	46.1	49.5	39.3	40.5	43.8	47.0	36.4	37.5	40.6	43.6
		S/T	0.84	0.75	0.57	0.37	0.87	0.78	0.59	0.38	0.38	0.90	0.80	0.61	0.39	0.93	0.83	0.63	0.40	0.96	0.86	0.65	0.42	0.97	0.87	0.66	0.42
		Delta T	22	20	16	11	22	20	16	11	11	22	20	16	11	22	20	17	11	22	20	16	11	20	19	15	11
75	1600	KW	3.09	3.15	3.24	3.34	3.31	3.37	3.47	3.57	3.50	3.57	3.67	3.78	3.66	3.74	3.85	3.97	3.81	3.88	4.00	4.13	3.93	4.01	4.13	4.26	
		AMPS	13.6	13.8	14.2	14.6	14.5	14.7	15.1	15.6	15.6	15.5	15.8	16.2	16.7	16.4	16.7	17.2	17.2	17.2	17.6	18.1	18.7	18.1	18.5	19.0	19.6
		HI PR	228	245	259	270	256	275	290	303	303	291	313	330	345	331	356	376	392	372	401	423	441	412	443	468	488
		LO PR	109	116	127	135	116	123	134	143	143	120	128	139	149	126	134	147	156	132	141	154	164	137	145	159	169
		MBh	41.1	42.3	45.8	49.1	40.1	41.3	44.7	48.0	48.0	39.2	40.3	43.7	46.8	38.2	39.3	42.6	45.7	36.3	37.4	40.5	43.4	33.6	34.6	37.5	40.2
		S/T	0.81	0.73	0.55	0.35	0.84	0.75	0.57	0.37	0.37	0.86	0.77	0.59	0.38	0.89	0.80	0.60	0.39	0.93	0.83	0.63	0.40	0.93	0.84	0.63	0.41
		Delta T	22	20	17	11	22	20	17	12	12	22	20	17	12	22	21	17	12	22	20	17	12	21	19	16	11
		KW	3.03	3.08	3.17	3.26	3.23	3.30	3.39	3.49	3.49	3.42	3.49	3.59	3.70	3.58	3.65	3.76	3.88	3.72	3.79	3.91	4.03	3.84	3.92	4.04	4.16
		AMPS	13.3	13.5	13.9	14.3	14.1	14.4	14.8	15.3	15.3	15.1	15.4	15.9	16.4	16.0	16.3	16.8	17.3	16.8	17.2	17.7	18.2	17.7	18.0	18.6	19.2
		HI PR	221	238	251	262	248	267	282	294	294	282	303	320	334	321	346	365	381	361	389	411	428	399	430	454	473
LO PR	106	113	123	131	112	119	130	139	139	116	124	135	144	122	130	142	151	128	136	149	159	133	141	154	164		

* Entering Indoor Dry Bulb Temperature

High and low pressures are measured at the liquid and suction access fittings.

NOTE: Shaded area is ACCA (TVA) conditions

MODEL: GPH1348H41**

EXPANDED PERFORMANCE DATA

COOLING OPERATION

Design Subcooling, 12±3 °F @ the liquid access fitting connection AHR1 95 test conditions. Design Superheat 8±3 °F @ the compressor suction access fitting connection.

IDB*	Airflow	Outdoor Ambient Temperature																									
		65				75				85				95				105				115					
		59	63	67	71	59	63	67	71	59	63	67	71	59	63	67	71	59	63	67	71	59	63	67	71		
80	1800	MBh	46.7	47.7	50.9	54.4	45.6	46.6	49.7	53.2	44.5	45.5	48.6	51.9	43.4	44.3	47.4	50.6	41.2	42.1	45.0	48.1	38.2	39.0	41.7	44.6	
		S/T	0.97	0.91	0.74	0.55	1.00	0.94	0.77	0.57	1.00	0.97	0.79	0.59	1.00	1.00	0.81	0.61	1.00	1.00	0.84	0.63	1.00	1.00	0.85	0.64	
		Delta T	23	22	19	15	23	22	20	16	23	22	20	16	22	23	20	16	21	21	22	19	15	20	20	18	14
		KW	3.14	3.20	3.29	3.39	3.36	3.42	3.52	3.63	3.55	3.62	3.73	3.84	3.72	3.80	3.91	4.03	3.86	3.94	4.07	4.19	3.99	4.07	4.20	4.33	
		AMPS	13.8	14.0	14.4	14.9	14.7	15.0	15.4	15.9	15.7	16.0	16.5	17.0	16.6	17.0	17.4	18.0	17.5	17.9	18.4	19.0	18.4	18.8	19.3	20.0	
		HI PR	232	250	264	275	261	281	296	309	297	319	337	351	338	363	384	400	380	409	432	450	420	452	477	498	
		LO PR	112	119	130	138	118	125	137	146	123	130	142	152	129	137	149	159	135	143	157	167	140	148	162	173	
		MBh	45.3	46.3	49.5	52.9	44.2	45.2	48.3	51.6	43.2	44.1	47.2	50.4	42.1	43.1	46.0	49.2	40.0	40.9	43.7	46.7	37.1	37.9	40.5	43.3	
		S/T	0.93	0.87	0.71	0.53	0.96	0.90	0.73	0.55	0.98	0.92	0.75	0.56	1.00	0.95	0.78	0.58	1.00	0.99	0.80	0.60	1.00	1.00	0.81	0.61	
		Delta T	24	23	20	16	24	23	20	16	24	23	20	16	24	24	21	17	25	24	21	17	25	24	21	17	15
1600	1600	KW	3.12	3.18	3.27	3.36	3.33	3.40	3.50	3.60	3.52	3.59	3.70	3.81	3.69	3.77	3.88	4.00	3.84	3.91	4.03	4.16	3.96	4.04	4.17	4.30	
		AMPS	13.7	13.9	14.3	14.7	14.6	14.9	15.3	15.7	15.6	15.9	16.4	16.9	16.5	16.8	17.3	17.9	17.4	17.7	18.2	18.8	18.3	18.6	19.2	19.8	
		HI PR	230	248	261	273	258	278	293	306	294	316	334	348	334	360	380	396	376	405	428	446	416	447	472	493	
		LO PR	110	118	128	137	117	124	136	144	121	129	141	150	127	136	148	158	134	142	155	165	138	147	160	171	
		MBh	41.8	42.7	45.6	48.8	40.8	41.7	44.6	47.7	39.9	40.7	43.5	46.5	38.9	39.7	42.5	45.4	36.9	37.8	40.3	43.1	34.2	35.0	37.4	39.9	
		S/T	0.89	0.84	0.68	0.51	0.92	0.87	0.71	0.53	0.95	0.89	0.72	0.54	0.98	0.92	0.75	0.56	1.02	0.95	0.78	0.58	1.02	0.96	0.78	0.58	
		Delta T	25	23	20	16	25	24	21	17	25	24	21	17	25	24	21	17	25	24	21	17	25	24	21	19	15
		KW	3.05	3.11	3.19	3.29	3.26	3.32	3.42	3.52	3.44	3.51	3.62	3.73	3.61	3.68	3.79	3.91	3.75	3.82	3.94	4.06	3.87	3.95	4.07	4.19	
		AMPS	13.4	13.6	14.0	14.4	14.3	14.5	14.9	15.4	15.2	15.6	16.0	16.5	16.1	16.4	16.9	17.4	17.0	17.3	17.8	18.4	17.8	18.2	18.7	19.3	
		HI PR	223	240	254	265	250	269	285	297	285	306	324	338	324	349	369	384	365	393	415	433	403	434	458	478	
LO PR	107	114	124	133	113	120	132	140	118	125	137	146	124	132	144	153	130	138	150	160	134	143	156	166			

IDB*	Airflow	Outdoor Ambient Temperature																									
		65				75				85				95				105				115					
		59	63	67	71	59	63	67	71	59	63	67	71	59	63	67	71	59	63	67	71	59	63	67	71		
85	1800	MBh	47.5	48.4	50.7	54.1	46.4	47.3	49.5	52.8	45.3	46.1	48.3	51.6	44.2	45.0	47.1	50.3	42.0	42.8	44.8	47.8	38.9	39.6	41.5	44.3	
		S/T	1.00	0.98	0.89	0.72	1.00	1.00	0.92	0.74	1.00	1.00	0.94	0.76	1.00	1.00	0.97	0.79	1.00	1.00	0.96	0.82	1.00	1.00	0.96	0.83	
		Delta T	24	24	23	20	24	24	23	20	23	24	23	20	23	23	23	20	21	22	23	20	20	20	21	19	19
		KW	3.16	3.22	3.31	3.41	3.38	3.45	3.55	3.66	3.58	3.65	3.76	3.87	3.75	3.82	3.94	4.06	3.89	3.98	4.10	4.23	4.02	4.10	4.23	4.37	
		AMPS	13.9	14.2	14.5	15.0	14.8	15.1	15.5	16.0	15.8	16.2	16.6	17.1	16.7	17.1	17.6	18.1	17.7	18.0	18.5	19.1	18.5	18.9	19.5	20.1	
		HI PR	235	253	267	278	263	283	299	312	300	322	340	355	341	367	388	404	384	413	436	455	424	456	482	503	
		LO PR	113	120	131	139	119	127	138	147	124	132	144	153	130	138	151	161	136	145	158	169	141	150	164	174	
		MBh	46.1	47.0	49.2	52.5	45.0	45.9	48.1	51.3	43.9	44.8	46.9	50.1	42.9	43.7	45.8	48.8	40.7	41.5	43.5	46.4	37.7	38.5	40.3	43.0	
		S/T	0.97	0.94	0.84	0.69	1.00	0.97	0.88	0.71	1.00	0.99	0.90	0.73	1.00	1.00	0.93	0.75	1.00	1.00	0.96	0.78	1.00	1.00	0.97	0.79	
		Delta T	26	25	24	21	26	26	24	21	25	26	24	21	25	25	24	21	23	24	24	21	22	22	22	19	19
1600	1600	KW	3.14	3.20	3.29	3.39	3.36	3.42	3.52	3.63	3.55	3.62	3.73	3.84	3.72	3.80	3.91	4.03	3.86	3.94	4.07	4.19	3.99	4.07	4.20	4.33	
		AMPS	13.8	14.0	14.4	14.9	14.7	15.0	15.4	15.9	15.7	16.0	16.5	17.0	16.6	17.0	17.4	18.0	17.5	17.9	18.4	19.0	18.4	18.8	19.3	20.0	
		HI PR	232	250	264	275	261	281	296	309	297	319	337	351	338	363	384	400	380	409	432	450	420	452	477	498	
		LO PR	112	119	130	138	118	125	137	146	123	130	142	152	129	137	149	159	135	143	157	167	140	148	162	173	
		MBh	42.5	43.4	45.4	48.5	41.5	42.4	44.4	47.3	40.6	41.3	43.3	46.2	39.6	40.3	42.2	45.1	37.6	38.3	40.1	42.8	34.8	35.5	37.2	39.7	
		S/T	0.94	0.90	0.81	0.66	0.97	0.94	0.84	0.69	0.99	0.96	0.87	0.70	1.00	0.99	0.89	0.73	1.00	1.00	0.93	0.75	1.00	1.00	0.94	0.76	
		Delta T	26	26	24	21	26	26	25	21	26	26	25	21	26	26	25	21	25	25	24	21	23	23	23	20	20
		KW	3.07	3.13	3.22	3.31	3.28	3.35	3.44	3.55	3.47	3.54	3.64	3.75	3.63	3.71	3.82	3.94	3.78	3.85	3.97	4.09	3.90	3.98	4.10	4.23	
		AMPS	13.5	13.7	14.1	14.5	14.4	14.6	15.0	15.5	15.4	15.7	16.1	16.6	16.2	16.6	17.0	17.6	17.1	17.5	18.0	18.5	18.0	18.3	18.9	19.5	
		HI PR	225	243	256	267	253	272	287	300	288	310	327	341	328	353	372	388	369	397	419	437	407	438	463	483	
LO PR	108	115	126	134	114	122	133	141	119	126	138	147	125	133	145	154	131	139	152	162	135	144	157	167			

* Entering Indoor Dry Bulb Temperature
 High and low pressures are measured at the liquid and suction access fittings.
 NOTE: Shaded area is AHR1 Rating Conditions
 KW = Total system power
 AMPS: Unit amps (comp. + evaporator + condenser fan motors)

COOLING PERFORMANCE DATA

GPH1360H41**

EXPANDED PERFORMANCE DATA

EXPANDED PERFORMANCE DATA

MODEL: GPH1360H41**

Design Subcooling, 12±3 °F @ the liquid access fitting connection AHRI 95 test conditions. Design Superheat 8±3 °F @ the compressor suction access fitting connection.

IDB*	Airflow	Outdoor Ambient Temperature												Cooling Operation																
		65				75				85				95				105				115								
		59	63	67	71	59	63	67	71	59	63	67	71	59	63	67	71	59	63	67	71	59	63	67	71					
70	2079	MBh	56.3	58.4	64.0	-	55.0	57.0	62.5	-	53.7	55.7	61.0	-	52.4	54.3	59.5	-	49.8	51.6	56.5	-	48.3	50.1	54.9	-	46.1	47.8	52.4	-
		S/T	0.75	0.62	0.43	-	0.77	0.65	0.45	-	0.79	0.66	0.46	-	0.82	0.68	0.47	-	0.85	0.71	0.49	-	0.88	0.71	0.49	-	0.86	0.71	0.50	-
		Delta T	19	16	12	-	19	16	12	-	19	16	12	-	19	16	12	-	19	16	12	-	19	16	12	-	17	15	11	-
		KW	3.85	3.93	4.06	-	4.15	4.24	4.37	-	4.41	4.50	4.65	-	4.64	4.74	4.89	-	4.83	4.94	5.10	-	5.00	5.11	5.28	-	5.00	5.11	5.28	-
		AMPS	16.2	16.5	17.0	-	17.4	17.7	18.3	-	18.7	19.1	19.7	-	19.9	20.3	20.9	-	21.0	20.5	22.2	-	22.2	22.7	23.4	-	22.2	22.7	23.4	-
		HI PR	233	250	264	-	261	281	296	-	297	319	337	-	338	364	384	-	380	409	432	-	420	452	477	-	420	452	477	-
		LO PR	107	114	124	-	113	120	131	-	118	125	137	-	124	131	144	-	130	138	150	-	134	143	156	-	134	143	156	-
		MBh	54.7	56.7	62.1	-	53.4	55.4	60.7	-	52.2	54.1	59.2	-	50.9	52.7	57.8	-	48.3	50.1	54.9	-	44.8	46.4	50.9	-	44.8	46.4	50.9	-
		S/T	0.71	0.59	0.41	-	0.74	0.62	0.43	-	0.76	0.63	0.44	-	0.78	0.65	0.45	-	0.81	0.68	0.47	-	0.82	0.68	0.47	-	0.82	0.68	0.47	-
		Delta T	19	17	13	-	20	17	13	-	20	17	13	-	20	17	13	-	19	17	13	-	18	16	12	-	18	16	12	-
75	1850	MBh	50.5	52.3	57.3	-	49.3	51.1	56.0	-	48.1	49.9	54.7	-	47.0	48.7	53.3	-	44.6	46.2	50.7	-	41.3	42.8	46.9	-	41.3	42.8	46.9	-
		S/T	0.69	0.57	0.40	-	0.71	0.59	0.41	-	0.73	0.61	0.42	-	0.75	0.63	0.44	-	0.78	0.65	0.45	-	0.79	0.66	0.46	-	0.79	0.66	0.46	-
		Delta T	20	17	13	-	20	17	13	-	20	17	13	-	20	17	13	-	20	17	13	-	20	17	13	-	18	16	12	-
		KW	3.73	3.81	3.93	-	4.02	4.10	4.23	-	4.27	4.36	4.50	-	4.48	4.58	4.73	-	4.67	4.77	4.93	-	4.83	4.94	5.10	-	4.83	4.94	5.10	-
		AMPS	15.7	16.0	16.5	-	16.8	17.2	17.7	-	18.1	18.5	19.0	-	19.2	19.6	20.2	-	20.3	20.8	21.4	-	21.4	21.9	22.6	-	21.4	21.9	22.6	-
		HI PR	223	240	254	-	251	270	285	-	285	307	324	-	325	349	369	-	365	393	415	-	403	434	458	-	403	434	458	-
		LO PR	103	109	120	-	109	116	126	-	113	120	131	-	119	126	138	-	124	132	144	-	129	137	149	-	129	137	149	-
		MBh	57.3	59.0	63.9	68.5	56.0	57.6	62.4	66.9	54.6	56.3	60.9	65.3	53.3	54.9	59.4	63.8	50.6	52.1	56.4	60.6	46.9	48.3	52.3	56.1				
		S/T	0.85	0.76	0.57	0.37	0.88	0.79	0.59	0.38	0.90	0.81	0.61	0.39	0.93	0.83	0.63	0.40	0.97	0.86	0.65	0.42	0.97	0.87	0.66	0.42				
		Delta T	21	20	16	11	22	20	16	11	22	20	16	11	22	20	17	11	22	20	16	11	20	19	15	11				
75	2079	KW	3.89	3.97	4.09	4.22	4.18	4.27	4.41	4.55	4.44	4.54	4.69	4.84	4.67	4.78	4.93	5.10	4.87	4.98	5.14	5.32	5.04	5.15	5.32	5.50				
		AMPS	16.3	16.7	17.2	17.7	17.5	17.9	18.4	19.0	18.9	19.3	19.9	20.5	20.0	20.5	21.1	21.8	21.2	21.7	22.3	23.1	22.4	22.9	23.6	24.4				
		HI PR	235	253	267	278	264	284	300	312	300	323	341	355	341	367	388	405	384	413	436	455	424	457	482	503				
		LO PR	108	115	126	134	114	122	133	141	119	126	138	147	125	133	145	154	131	139	152	162	135	144	157	167				
		MBh	55.6	57.3	62.0	66.5	54.3	55.9	60.6	65.0	53.0	54.6	59.1	63.4	51.8	53.3	57.7	61.9	49.2	50.6	54.8	58.8	45.5	46.9	50.8	54.5				
		S/T	0.81	0.72	0.55	0.35	0.84	0.75	0.57	0.36	0.86	0.77	0.58	0.37	0.89	0.79	0.60	0.39	0.92	0.82	0.62	0.40	0.93	0.83	0.63	0.40				
		Delta T	22	21	17	12	23	21	17	12	23	21	17	12	23	21	17	12	22	21	17	12	21	19	16	11				
		KW	3.85	3.94	4.06	4.19	4.15	4.24	4.37	4.51	4.41	4.50	4.65	4.80	4.64	4.74	4.89	5.06	4.83	4.94	5.10	5.27	5.00	5.11	5.28	5.46				
		AMPS	16.2	16.5	17.0	17.6	17.4	17.7	18.3	18.9	18.7	19.1	19.7	20.4	19.9	20.3	20.9	21.6	21.0	21.5	22.2	22.9	22.2	22.7	23.4	24.2				
		HI PR	233	250	264	276	261	281	297	309	297	319	337	352	338	364	384	401	380	409	432	451	420	452	477	498				
LO PR	107	114	124	133	113	120	131	140	118	125	137	146	124	131	144	153	130	138	150	160	134	143	156	166						
75	1850	MBh	51.3	52.9	57.2	61.4	50.2	51.6	55.9	60.0	49.0	50.4	54.6	58.6	47.8	49.2	53.2	57.1	45.4	46.7	50.6	54.3	42.0	43.3	46.8	50.3				
		S/T	0.78	0.70	0.53	0.34	0.81	0.72	0.55	0.35	0.83	0.74	0.56	0.36	0.86	0.76	0.58	0.37	0.89	0.79	0.60	0.39	0.89	0.80	0.61	0.39				
		Delta T	23	21	17	12	23	21	17	12	23	21	17	12	23	21	17	12	23	21	17	12	21	20	16	11				
		KW	3.76	3.84	3.96	4.09	4.05	4.13	4.27	4.40	4.30	4.39	4.53	4.68	4.52	4.62	4.77	4.93	4.71	4.81	4.97	5.14	4.87	4.98	5.15	5.32				
		AMPS	15.8	16.1	16.6	17.2	16.9	17.3	17.8	18.4	18.2	18.6	19.2	19.8	19.4	19.8	20.4	21.1	20.5	20.9	21.6	22.3	21.6	22.1	22.8	23.6				
		HI PR	226	243	256	267	253	272	288	300	288	310	327	341	328	353	373	389	369	397	419	437	408	439	463	483				
		LO PR	104	111	121	129	110	117	128	136	114	121	133	141	120	128	139	148	126	134	146	155	130	138	151	161				

* IDB: Entering Indoor Dry Bulb Temperature

High and low pressures are measured at the liquid and suction access fittings.

NOTE: Shaded area is ACCA (TVA) condition

MODEL: GPH1360H41**

EXPANDED PERFORMANCE DATA

COOLING OPERATION

Design Subcooling, 12.33 °F @ the liquid access fitting connection AHR1 95 test conditions. Design Superheat 8.3 °F @ the compressor suction access fitting connection.

IDB*	Airflow	Outdoor Ambient Temperature																								
		65				75				85				95				105				115				
		59	63	67	71	59	63	67	71	59	63	67	71	59	63	67	71	59	63	67	71	59	63	67	71	
80	2079	MBh	58.3	59.6	63.7	68.1	57.0	58.2	62.2	66.5	55.6	56.8	60.7	64.9	54.3	55.4	59.2	63.3	51.5	52.7	56.3	60.1	47.7	48.8	52.1	55.7
		S/T	0.93	0.87	0.71	0.53	0.96	0.90	0.74	0.55	1.00	0.93	0.75	0.56	1.00	0.96	0.78	0.58	1.00	1.00	0.81	0.60	1.00	1.00	0.81	0.61
		Delta T	24	23	20	16	24	23	20	16	25	23	20	16	24	23	20	16	23	23	20	16	21	22	19	15
		KW	3.92	4.00	4.12	4.26	4.22	4.31	4.44	4.59	4.48	4.58	4.73	4.88	4.71	4.82	4.98	5.14	4.91	5.02	5.19	5.36	5.08	5.20	5.37	5.55
		AMPS	16.5	16.8	17.3	17.9	17.6	18.0	18.6	19.2	19.0	19.4	20.0	20.7	20.2	20.6	21.3	22.0	21.4	21.9	22.5	23.3	22.5	23.1	23.8	24.6
	1850	HI PR	237	255	270	281	266	286	303	316	303	326	344	359	345	371	392	409	388	417	441	460	429	461	487	508
		LO PR	109	116	127	135	116	123	134	143	120	128	139	148	126	134	146	156	132	141	153	163	137	145	159	169
		MBh	56.6	57.9	61.8	66.1	55.3	56.5	60.4	64.5	54.0	55.2	58.9	63.0	52.7	53.8	57.5	61.5	50.0	51.1	54.6	58.4	46.3	47.4	50.6	54.1
		S/T	0.89	0.83	0.68	0.51	0.92	0.86	0.70	0.52	0.94	0.88	0.72	0.54	0.97	0.91	0.74	0.55	1.00	0.95	0.77	0.58	1.00	0.95	0.78	0.58
		Delta T	25	24	21	17	25	24	21	17	25	24	21	17	25	24	21	17	25	24	21	17	23	22	20	16
1621	KW	3.89	3.97	4.09	4.22	4.18	4.27	4.41	4.55	4.44	4.54	4.69	4.84	4.68	4.78	4.93	5.10	4.87	4.98	5.14	5.32	5.04	5.15	5.32	5.50	
	AMPS	16.3	16.7	17.2	17.7	17.5	17.9	18.4	19.0	18.9	19.3	19.9	20.5	20.0	20.5	21.1	21.8	21.2	21.7	22.3	23.1	22.4	22.9	23.6	24.4	
	HI PR	235	253	267	278	264	284	300	312	300	323	341	355	341	367	388	405	384	413	437	455	424	457	482	503	
	LO PR	108	115	126	134	114	122	133	141	119	126	138	147	125	133	145	154	131	139	152	162	135	144	157	167	
	MBh	52.3	53.4	57.1	61.0	51.0	52.2	55.7	59.6	49.8	50.9	54.4	58.2	48.6	49.7	53.1	56.7	46.2	47.2	50.4	53.9	42.8	43.7	46.7	49.9	

GPH1360H41**

85	2079	MBh	59.3	60.5	63.3	67.6	58.0	59.1	61.9	66.0	56.6	57.7	60.4	64.4	55.2	56.3	58.9	62.9	52.4	53.5	56.0	59.7	48.6	49.5	51.9	55.3
		S/T	0.97	0.94	0.85	0.69	1.00	0.97	0.88	0.71	1.00	1.00	0.90	0.73	1.00	1.00	0.93	0.76	1.00	1.00	0.97	0.78	1.00	1.00	0.97	0.79
		Delta T	26	25	24	21	26	25	24	21	25	25	24	21	24	25	24	21	23	24	24	21	21	22	22	19
		KW	3.95	4.03	4.16	4.29	4.25	4.34	4.48	4.63	4.52	4.62	4.77	4.92	4.75	4.86	5.02	5.18	4.95	5.06	5.23	5.41	5.13	5.24	5.42	5.60
		AMPS	16.6	16.9	17.4	18.0	17.8	18.2	18.7	19.3	19.2	19.6	20.2	20.9	20.4	20.8	21.5	22.2	21.6	22.0	22.7	23.5	22.7	23.3	24.0	24.8
	1850	HI PR	240	258	272	284	269	289	306	319	306	329	348	362	348	375	396	413	392	422	445	464	433	466	492	513
		LO PR	110	117	128	137	117	124	135	144	121	129	141	150	127	135	148	158	133	142	155	165	138	147	160	171
		MBh	57.6	58.7	61.5	65.6	56.3	57.4	60.1	64.1	54.9	56.0	58.6	62.6	53.6	54.6	57.2	61.0	50.9	51.9	54.4	58.0	47.2	48.1	50.3	53.7
		S/T	0.93	0.90	0.81	0.66	0.96	0.93	0.84	0.68	0.99	0.95	0.86	0.70	1.00	0.98	0.89	0.72	1.00	1.00	0.92	0.75	1.00	1.00	0.93	0.75
		Delta T	27	26	25	21	27	26	25	22	27	27	25	22	27	27	25	22	25	26	25	22	23	24	23	20
1621	KW	3.92	4.00	4.12	4.26	4.22	4.31	4.44	4.59	4.48	4.58	4.73	4.88	4.71	4.82	4.98	5.14	4.91	5.02	5.19	5.36	5.08	5.20	5.37	5.55	
	AMPS	16.5	16.8	17.3	17.9	17.6	18.0	18.6	19.2	19.0	19.4	20.0	20.7	20.2	20.6	21.3	22.0	21.4	21.9	22.5	23.3	22.5	23.1	23.8	24.6	
	HI PR	237	255	270	281	266	286	303	316	303	326	344	359	345	371	392	409	388	417	441	460	429	461	487	508	
	LO PR	109	116	127	135	116	123	134	143	120	128	139	148	126	134	146	156	132	141	153	163	137	145	159	169	
	MBh	53.2	54.2	56.8	60.6	51.9	52.9	55.4	59.2	50.7	51.7	54.1	57.7	49.5	50.4	52.8	56.3	47.0	47.9	50.2	53.5	43.5	44.4	46.5	49.6	

* Entering Indoor Dry Bulb Temperature
 High and low pressures are measured at the liquid and suction access fittings.
 NOTE: Shaded area is AHR1 Rating Conditions
 KW = Total system power
 AMPS: Unit amps (comp.+ evaporator + condenser fan motors)

PACKAGE HEAT PUMP SPECIFICATIONS GPH13[24-36]H41**

EXPANDED PERFORMANCE DATA

MODEL: GPH1324H41*

HEATING OPERATION

	Outdoor Ambient Temperature																	
	65	60	55	50	47	45	40	35	30	25	20	17	15	10	5	0	-5	-10
MBh	27.7	26.2	24.6	23.0	22.0	21.3	19.8	18.3	17.4	16.1	14.8	14.0	13.5	12.1	10.7	9.4	8.0	6.5
DELTA T	29.3	27.7	26.1	24.4	23.3	22.6	21.0	19.3	18.5	17.0	15.7	14.8	14.3	12.8	11.3	9.9	8.4	6.9
KW	2.01	1.97	1.94	1.90	1.88	1.86	1.82	1.78	1.82	1.78	1.74	1.72	1.70	1.66	1.62	1.58	1.54	1.50
AMPS	9.6	9.0	8.5	8.1	7.8	7.7	7.3	7.0	6.7	6.5	6.2	6.1	6.0	5.8	5.5	5.2	4.9	4.5
COP	4.02	3.88	3.73	3.55	3.43	3.36	3.18	3.00	2.81	2.65	2.50	2.39	2.32	2.13	1.94	1.73	1.52	1.28
EER	13.7	13.3	12.7	12.1	11.7	11.5	10.9	10.2	9.6	9.1	8.5	8.2	7.9	7.3	6.6	5.9	5.2	4.4
HI PR	366	351	337	323	315	309	297	285	273	261	251	245	240	231	222	213	205	198
LO PR	132	122	114	105	99	95	88	78	70	63	55	51	50	42	36	31	27	21

Above information is for nominal CFM and 70 degree indoor dry bulb. Instantaneous capacity listed.

MODEL: GPH1330H41A*

HEATING OPERATION

	Outdoor Ambient Temperature																	
	65	60	55	50	47	45	40	35	30	25	20	17	15	10	5	0	-5	-10
MBh	33.9	32.1	30.2	28.3	27.0	26.2	24.3	22.4	19.8	18.2	16.8	15.9	15.3	13.7	12.1	10.6	9.0	7.4
DELTA T	29.9	28.3	26.7	24.9	23.8	23.1	21.4	19.8	17.4	16.1	14.8	14.0	13.5	12.1	10.7	9.3	8.0	6.5
KW	2.43	2.39	2.34	2.29	2.27	2.25	2.20	2.16	2.50	2.44	2.38	2.35	2.33	2.27	2.21	2.16	2.10	2.04
AMPS	12.1	11.3	10.7	10.1	9.8	9.6	9.2	8.8	8.5	8.1	7.8	7.7	7.6	7.2	6.9	6.5	6.1	5.7
COP	4.08	3.94	3.78	3.61	3.49	3.41	3.23	3.04	2.32	2.19	2.06	1.98	1.92	1.77	1.61	1.44	1.26	1.06
EER	14.0	13.5	12.9	12.3	11.9	11.6	11.0	10.4	7.9	7.5	7.0	6.7	6.6	6.0	5.5	4.9	4.3	3.6
HI PR	384	368	354	338	331	324	312	299	287	274	263	256	252	242	233	223	215	208
LO PR	132	122	115	105	99	96	88	78	71	63	55	52	50	42	36	31	27	21

Above information is for nominal CFM and 70 degree indoor dry bulb. Instantaneous capacity listed.

MODEL: GPH1336H41A*

HEATING OPERATION

	Outdoor Ambient Temperature																	
	65	60	55	50	47	45	40	35	30	25	20	17	15	10	5	0	-5	-10
MBh	42.2	40.0	37.6	35.2	33.6	32.6	30.2	27.9	22.4	20.7	19.1	18.0	17.3	15.6	13.8	12.0	10.3	8.4
DELTA T	32.6	30.9	29.0	27.1	25.9	25.1	23.3	21.5	17.3	16.0	14.7	13.9	13.4	12.0	10.6	9.3	7.9	6.5
KW	2.99	2.94	2.88	2.82	2.79	2.77	2.72	2.66	2.76	2.70	2.64	2.61	2.58	2.52	2.47	2.41	2.35	2.29
AMPS	14.8	13.9	13.1	12.5	12.1	11.9	11.3	10.8	10.5	10.1	9.7	9.5	9.4	9.0	8.6	8.2	7.7	7.1
COP	4.13	3.99	3.82	3.64	3.52	3.44	3.26	3.07	2.38	2.24	2.11	2.02	1.96	1.80	1.64	1.46	1.28	1.07
EER	14.1	13.6	13.1	12.5	12.0	11.8	11.1	10.5	8.1	7.7	7.2	6.9	6.7	6.2	5.6	5.0	4.4	3.7
HI PR	368	353	339	324	317	311	299	287	274	262	252	246	241	232	223	214	206	199
LO PR	134	125	117	107	101	97	90	80	72	64	57	53	51	43	37	31	27	21

Above information is for nominal CFM and 70 degree indoor dry bulb. Instantaneous capacity listed.

MODEL: GPH1342H41A*

HEATING OPERATION

	Outdoor Ambient Temperature																	
	65	60	55	50	47	45	40	35	30	25	20	17	15	10	5	0	-5	-10
MBh	47.8	45.2	42.6	39.8	38.0	36.8	34.2	31.5	27.4	25.3	23.3	22.0	21.2	19.0	16.9	14.7	12.5	10.3
DELTA T	31.4	29.7	27.9	26.1	25.0	24.2	22.5	20.7	18.0	16.6	15.3	14.4	13.9	12.5	11.1	9.7	8.2	6.7
KW	3.27	3.21	3.15	3.09	3.06	3.04	2.98	2.92	3.03	2.97	2.90	2.87	2.84	2.78	2.71	2.65	2.59	2.53
AMPS	11.9	11.2	10.7	10.2	9.9	9.8	9.4	9.0	8.8	8.5	8.2	8.1	8.0	7.8	7.4	7.1	6.8	6.4
COP	4.27	4.12	3.95	3.76	3.63	3.55	3.36	3.16	2.65	2.50	2.35	2.25	2.18	2.00	1.82	1.62	1.42	1.19
EER	14.6	14.1	13.5	12.9	12.4	12.1	11.5	10.8	9.0	8.5	8.0	7.7	7.5	6.8	6.2	5.5	4.8	4.1
HI PR	355	341	327	313	306	300	288	277	265	253	243	237	233	224	216	207	199	192
LO PR	130	121	113	104	98	94	87	77	70	62	55	51	49	41	36	30	26	21

Above information is for nominal CFM and 70 degree indoor dry bulb. Instantaneous capacity listed.

PACKAGE HEAT PUMP SPECIFICATIONS GPH13[42-60]H41**

EXPANDED PERFORMANCE DATA

MODEL: GPH1348H41**

HEATING OPERATION

	Outdoor Ambient Temperature																	
	65	60	55	50	47	45	40	35	30	25	20	17	15	10	5	0	-5	-10
MBh	55.9	53.0	49.8	46.6	44.5	43.1	40.1	36.9	32.4	29.9	27.5	26.0	25.0	22.5	19.9	17.4	14.8	12.1
DELTA T	32.4	30.6	28.8	27.0	25.8	25.0	23.2	21.4	18.7	17.3	15.9	15.0	14.5	13.0	11.5	10.1	8.6	7.0
KW	3.72	3.65	3.58	3.52	3.48	3.45	3.38	3.32	3.40	3.33	3.26	3.22	3.19	3.12	3.05	2.98	2.90	2.83
AMPS	19.1	17.9	16.9	16.1	15.6	15.4	14.6	14.0	13.5	13.1	12.6	12.3	12.2	11.7	11.1	10.6	10.0	9.3
COP	4.40	4.24	4.07	3.88	3.74	3.66	3.46	3.26	2.79	2.63	2.47	2.37	2.30	2.11	1.91	1.71	1.49	1.25
EER	15.0	14.5	13.9	13.2	12.8	12.5	11.8	11.1	9.5	9.0	8.4	8.1	7.9	7.2	6.5	5.8	5.1	4.3
HI PR	366	351	337	323	315	309	297	285	273	261	250	244	240	231	222	213	205	198
LO PR	130	121	113	104	98	94	87	77	70	62	55	51	49	41	36	30	26	21

Above information is for nominal CFM and 70 degree indoor dry bulb. Instantaneous capacity listed.

MODEL: GPH1360H41*

HEATING OPERATION

	Outdoor Ambient Temperature																	
	65	60	55	50	47	45	40	35	30	25	20	17	15	10	5	0	-5	-10
MBh	68.5	64.9	61.0	57.1	54.5	52.8	49.1	45.2	39.9	36.8	33.9	32.0	30.8	27.6	24.5	21.4	18.2	14.9
DELTA T	34.3	32.5	30.6	28.6	27.3	26.4	24.5	22.6	20.0	18.4	17.0	16.0	15.4	13.8	12.3	10.7	9.1	7.5
KW	5.30	5.19	5.09	4.98	4.92	4.87	4.77	4.67	41.89	40.71	39.57	38.88	38.42	37.24	36.10	34.96	33.78	32.64
AMPS	22.8	21.3	20.1	19.0	18.4	18.0	17.1	16.3	15.7	15.1	14.5	14.2	14.0	13.4	12.6	12.0	11.2	10.3
COP	3.78	3.65	3.51	3.35	3.24	3.17	3.01	2.84	0.28	0.26	0.25	0.24	0.23	0.22	0.20	0.18	0.16	0.13
EER	12.9	12.5	12.0	11.5	11.1	10.8	10.3	9.7	1.0	0.9	0.9	0.8	0.8	0.7	0.7	0.6	0.5	0.5
HI PR	370	354	341	326	318	312	300	288	276	263	253	247	242	233	224	215	207	200
LO PR	125	116	108	99	94	90	83	74	67	60	52	49	47	40	34	29	25	20

Above information is for nominal CFM and 70 degree indoor dry bulb. Instantaneous capacity listed.

PERFORMANCE TEST

All data based upon listed indoor dry bulb temperature. .00 inches external static pressure on coil of outdoor section. Indoor air cubic feet per minute (CFM) as listed in the Performance Data Sheets:

If conditions vary from this, results will change as follows:

1. As indoor dry bulb temperatures increase, a slight increase will occur in indoor air temperature drop (Delta T). Low and high side pressures and power will not change.
2. As indoor CFM decreases, a slight increase will occur in indoor temperature drop (Delta T). A slight decrease will occur in low and high side pressures and power.

A properly operating unit should be within plus or minus **3 degrees** of the typical (**Delta T**) value shown.

A properly operating unit should be within plus or minus **7 PSIG** of the **HI PR** shown.

A properly operating unit should be within plus or minus **3 PSIG** of the **LO PR** shown.

A properly operating unit should be within plus or minus **3 Amps** of the typical value shown.

WIRING DIAGRAMS

GPH1324, 30, 42H41AB / GPH1336H41AC

GPH1348H41BB

WARNING
 HIGH VOLTAGE!
 DISCONNECT ALL POWER BEFORE SERVICING OR INSTALLING THIS UNIT. MULTIPLE POWER SOURCES MAY BE PRESENT. FAILURE TO DO SO MAY CAUSE PROPERTY DAMAGE, PERSONAL INJURY OR DEATH.

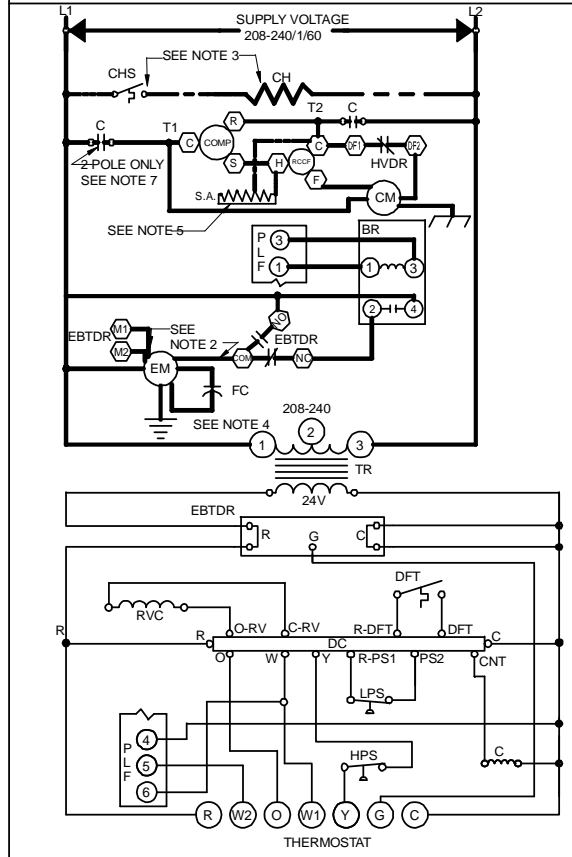
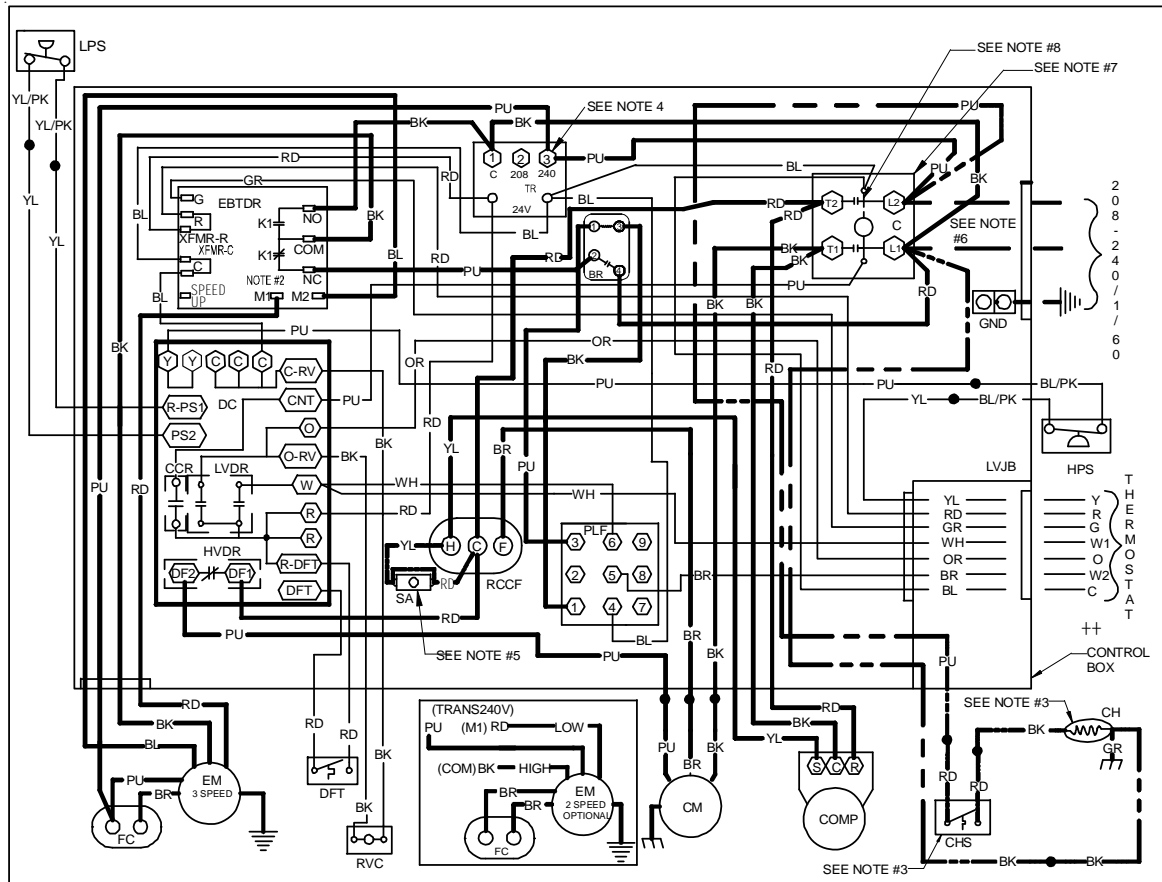

COMPONENT LEGEND

BR	BLOWER INTERLOCK RELAY	---	FACTORY WIRING
C	CONTACTOR	---	LINE VOLTAGE
CCR	COMPRESSOR CONTACTOR RELAY	---	LOW VOLTAGE
CH	CRANKCASE HEATER	---	OPTIONAL HIGH VOLTAGE
CHS	CRANKCASE HEATER SWITCH	---	VOLTAGE
CM	CONDENSER MOTOR	---	FIELD WIRING
COMP	COMPRESSOR	---	HIGH VOLTAGE
DC	DEFROST CONTROL	---	LOW VOLTAGE
DFT	DEFROST THERMOSTAT		
EBTDR	ELECTRONIC BLOWER TIME DELAY RELAY		
EM	EVAPORATOR MOTOR		
FC	FAN CAPACITOR		
GND	EQUIPMENT GROUND		
HPS	HIGH PRESSURE SWITCH		
HVDR	HIGH VOLTAGE DEFROST RELAY		
LPS	LOW PRESSURE SWITCH		
LVDR	LOW VOLTAGE DEFROST RELAY		
LVJB	LOW VOLTAGE JUNCTION BOX		
PLF	FEMALE PLUG / CONNECTOR		
RVC	REVERSING VALVE COIL		
RCCF	RUN CAPACITOR FOR COMPRESSOR AND FAN		
SA	START ASSIST		
TR	TRANSFORMER		

WIRE CODE

BK	BLACK
BL	BLUE
BR	BROWN
GR	GREEN
OR	ORANGE
PU	PURPLE
RD	RED
WH	WHITE
YL	YELLOW

- NOTES:**
- REPLACEMENT WIRE MUST BE SAME SIZE AND TYPE INSULATION AS ORIGINAL (AT LEAST 105°C) USE COPPER CONDUCTOR ONLY.
 - TO CHANGE EVAPORATOR MOTOR SPEED REPLACE LEAD ON EBTDR "COM" WITH LEAD ON EBTDR "M1" OR "M2".
 - CRANKCASE HEATER AND CRANKCASE HEATER SWITCH FACTORY EQUIPPED WHEN REQUIRED.
 - FOR 208 VOLT TRANSFORMER OPERATION MOVE PURPLE WIRES FROM TERMINAL 3 TERMINAL 2 ON TRANSFORMER.
 - START ASSIST FACTORY EQUIPPED WHEN REQUIRED.
 - USE COPPER CONDUCTORS ONLY ++ USE N.E.C. CLASS 2 WIRE.
 - DOUBLE POLE CONTACTOR SHOWN. SINGLE POLE CONTACTOR COULD BE FACTORY EQUIPPED AS AN ALTERNATE CONFIGURATION.
 - COMMON SIDE OF CONTACTOR CAN NOT BE GROUNDED OR CONNECTED TO ANY OTHER COMMON (24V).

SEE UNIT RATING PLATE FOR TYPE AND SIZE OF OVER CURRENT PROTECTION

208-240/1/60 0140G01745-A

Wiring is subject to change, always refer to the wiring diagram on the unit for the most up-to-date wiring.

